

TRABAJO ESPECIAL DE GRADO

TÚNELES CON MÉTODO MECÁNICO A SECCIÓN PLENA: ESTUDIO DE LA INYECCIÓN DEL ESPACIO ANULAR DE COLA

Tutores Académicos: Prof. Ing. Peila, Daniele
Prof. Ing. Pelizza, Sebastiano
Dr. Ing. Borio, Luca

Presentado ante la Ilustre
Universidad Central de Venezuela

Por el Br.:

Apellidos, Nombres

Veriuska Ortiz Lovera

Para optar al Título de
Ingeniero Civil

En el marco del convenio de doble titulación con el Politecnico di Torino

Caracas, 2010

Ortiz L Veriuska

TÚNELES CON MÉTODO MECÁNICO A SECCIÓN PLENA: ESTUDIO DE LA INYECCIÓN DEL ESPACIO ANULAR DE COLA

Tutores Académico: Prof. Ing. Peila, Daniele; Prof. Ing. Pelizza, Sebastiano; Dr. Ing. Borio, Luca

Trabajo Especial de Grado. Caracas, U.C.V. Facultad de Ingeniería.

Escuela de Ingeniería Civil. 2010, n° pág: 141.

Palabras Clave: TBM, EPB, túneles, modelos numéricos, backfill grouting.

Resumen:

Las obras subterráneas han tenido una evolución significativa en el tiempo; hasta hace algunos años la excavación de túneles en terrenos con baja resistencia mecánica era casi imposible. La creación de las máquinas a sección plena (topas), específicamente aquellas con el frente de excavación bajo presión, ha permitido la conquista de nuevos ámbitos y el mayor aprovechamiento del espacio subterráneo, por ejemplo, en zonas urbanas, en cuyo caso es requerido un grado de perturbación mínimo.

Hasta el momento el control de los asentamientos producto de la excavación de túneles se ha focalizado en la aplicación de presión en el frente de la máquina. Sin embargo, actualmente ha crecido el interés por minimizar los desplazamientos ocurridos luego que la excavadora ha pasado. Las inyecciones del espacio anular de cola tienen el objetivo de detener las deformaciones producidas en la cola del escudo y luego de la instalación de los primeros revestimientos. Su aplicación consiste en introducir determinados materiales entre el anillo de concreto y el terreno, impidiendo la disipación de tensiones en este último y su inclusión dentro del túnel.

El comportamiento del túnel desde el montaje del revestimiento y el endurecimiento de la lechada en el espacio anular es incierto. Existe escasa información teórica referida a la fase de inyección y a cuáles son los mecanismos a los que se ven sometido tanto el terreno como los segmentos

de concreto. Asimismo no está del todo claro el comportamiento del grout, en cuanto a cómo se deforma o cambia su volumen hasta que desarrolla su resistencia final. El objetivo de este trabajo de grado es el de estudiar la eficiencia y los efectos de las inyecciones efectuadas en la parte posterior del escudo, en la construcción de túneles.

La investigación fue realizada en varias fases. Durante la primera fase se recopiló la información disponible para componer el estado del arte sobre las técnicas de inyección; se tuvieron en cuenta también los parámetros empíricos que son usualmente usados, variables según las condiciones de operación. Seguidamente, fueron estudiados los distintos tipos de materiales de inyección, sus propiedades, su aplicabilidad y el desempeño durante la etapa de excavación.

Finalmente, se construyeron sendos modelos analíticos y numéricos para evaluar el comportamiento de la lechada aún en estado líquido, que fueron útiles para comparar los diversos tipos de maltas y los parámetros que tienen que ver con el proceso de inyección.

A través de estas simulaciones se obtuvo que el uso de las inyecciones de cola reduce notablemente el volumen de terreno que deformado hacia el interior del espacio anular, trayendo como consecuencia una disminución de la subsidencia de hasta 300%.

POLITECNICO DI TORINO
I Facoltà di Ingegneria
Corso di Laurea Specialistica in Ingegneria per l'ambiente e il territorio

TESI DI LAUREA MAGISTRALE

**TUNNELLING WITH FULL FACE SHIELD MACHINES: Study of the backfill of
the tail void**

**SCAVO DI GALLERIE CON SCUDI A PIENA SEZIONE: Studio dell'iniezioni di
intasamento a tergo dello scudo**

Relatori:
Prof. Ing. Peila, Daniele
Prof. Ing. Pelizza, Sebastiano
Dr. Ing. Borio, Luca

Candidata:
Veriuska Ortiz Lovera

Luglio, 2010

ABSTRACT

The underground works have evolved in time; few years ago the excavation in soft ground was almost impossible. The invention of the Tunnel Boring machines, more specifically pressurized face ones, have permitted reaching new scopes and the utilisation of underground space in urban areas. Urban areas present critical conditions for tunnel excavation mainly due to the impact of the subsidence on the stability of buildings.

The soft ground tunnelling has focused the settlement control in the optimisation of the face pressures. However within the years the interest about the ground settlements after the tail of the machine has arised. The tail void grouting is a procedure aimed to control the deformations after the passage of the TBM, injecting material between lining and ground to stop the relaxation and the insertion of the soil inside the tunnel

The available theoretical information about this phase in the tunnel construction is minimum. The behaviour of the tunnel after the lining assembling is uncertain, and the performance of the grout during the injection and till it hardens has not been extensively analyzed in technical literature.

The objective of this project is to study the grouting performance and its influence to the construction process.

This task was reached in first place through the collection of the available information about the topic. It was done a wide research about the known theoretical aspects and the uncertainties that are already present regarding the backfill procedure. Afterwards, they were examined the operational procedures, mostly empirical, to build a database for subsequent theoretical investigation. Different injection materials, their properties, their applicability and performance were studied.

This research project was concluded with the setup of numerical and analytical models, to assess the behaviour of the grout during tunnel construction. These models made possible comparisons between different injection materials and other parameters regarding the injection process

RIASSUNTO

Le opere di scavo hanno avuto un'evoluzione nel tempo; fino a pochi anni fa lo scavo in terreni soffici era quasi impossibile. La creazione delle macchine a piena sezione, specificamente quelle a fronte in pressione, hanno permesso di conquistare nuovi ambiti ed approfittare gli spazi sotterranei. Le aree urbane in cui viene richiesto un grado di disturbo minimo costituiscono condizioni critiche per lo scavo di gallerie, dovuto all'influenza del fenomeno di subsidenza sull' stabilità degli edifici.

Finora lo scavo di gallerie si è focalizzato sul controllo dei cedimenti attraverso le pressioni al fronte. Tuttavia, con il passare degli anni è cresciuto l'interesse sugli spostamenti avvenuti dopo l'avanzamento della macchina. Le iniezioni di coda hanno l'obiettivo di fermare le deformazioni quando la TBM è passata, introducendo il materiale tra rivestimento e terreno, impedendo il rilassamento successivo di quest'ultimo e la sua inclusione all'interno della galleria.

Il comportamento della galleria tra il montaggio dei conci e l'indurimento della boiaccia è incerto. Esiste scarsa informazione teorica riguardante la fase d'iniezione e quali sono i meccanismi a cui sono soggetti sia il terreno che il rivestimento. Analogamente non è del tutto chiaro il comportamento del grout, ovvero come si deforma o cambia il suo volume finché sviluppa la sua resistenza finale. Lo scopo di questo progetto è studiare le prestazioni ed effetti delle iniezioni a tergo dello scudo nella costruzione delle gallerie.

La ricerca è stata sviluppata in diverse fasi. Durante la prima fase è stata ricavata l'informazione necessaria e disponibile per comporre lo stato dell'arte sulle tecniche d'iniezione; si è tenuto conto anche dei parametri empirici che vengono utilizzati durante le procedure di scavo e che sono variabili a seconda delle condizioni di operazione. In seguito, sono stati anche studiati i diversi tipi di materiale d'iniezione, le loro proprietà e l'applicabilità e disimpegno durante la fase di scavo.

Il progetto di ricerca è stato finalizzato con la costruzione di modelli sia analitici che numerici per valutare il comportamento della boiaccia ancora fluida, che hanno permesso di confrontare i diversi tipi di malte e i parametri che riguardano il processo d'iniezione.

ACKNOWLEDGMENTS

This thesis is the concluding work of my pre-grade studies. It represents the growth that I have had in all these years, academically and personally. I want to express my gratitude to the Professor Daniele Peila, for giving me the opportunity of working with him, for all the guidance, the patience and the support that he offered me along this time.

I also want to express my gratitude to the Eng Rene Ramirez, the Eng. Alessandro Boscaro and the Eng. Enzo Foti, for the helpful information that they provide me.

I thank the Professor Maria Eugenia Korody of the UCV, for being my tutor all these years, and help me when I need it. I am immensely grateful to the Professors at the Politecnico di Torino and at the Universidad Central de Venezuela for assist me during my career and provide so much knowledge. I am deeply indebted to my university colleagues, for this time full of experiences, inside and outside the classrooms, who contribute to make me the person that I am today.

I want to thank Vladimir and Cristina, for help me in some many ways, I could not do it without you. Thank you for all the valuable advices, the guidance and the patient.

I am grateful to Jorge, for being my biggest support, to my mother for always believe in me, to my dad for giving me everything, and to my brother and sisters, a huge inspiration for me.

Thanks indeed to all that made it possible.

CONTENTS

PREFACE	11
CHAPTER 1.....	12
BACKFILL OF THE TAIL VOID.....	12
1. Definition	12
2. Objectives-Function.....	13
3. Types of Backfill Grouting	14
a. Used Methodology	14
b. Used Materials.....	17
4. Design Parameters of the backfill material. Ideal Features	24
5. Resistance Requirements.....	26
6. Theoretical Description. Rheology	26
7. Backfill in Rocks	28
8. Control of the backfill process	29
• Control of grout volumes	29
• Control of backfill pressures.....	30
• Checking the mortar characteristics.	30
CHAPTER 2.....	31
INJECTION PRESSURES	31
1. Backfill in presence of seepage water. Erosion of the grout in the annular gap	33
2. Penetration of the grout	34
CHAPTER 3.....	50
PRECAST SEGMENTAL LINING AND BACKFILL GROUTING INFLUENCE.	50

1. Behaviour of the grout around the tunnel. Affection to the lining.....	57
a. Pressures around the tunnel	57
<i>Figure 30</i> Measured pressures in the Sophia Rail Tunnel.(Bezuijen et al 2004)	58
b. Bleeding and Hardening. Consequences.....	63
c. Gradients around the tunnel.....	64
CHAPTER 4.....	68
QUALITY CONTROL METHODS.....	68
1. Grading Curves of the aggregates	69
2. Compression Strength	69
3. Bleeding and volume loss	70
4. Workability:.....	73
5. Durability.....	76
6. Shear Strength.....	76
Politecnico di Torino Tests.....	77
• Bleeding test:.....	77
• Marsh cone test with nozzle of 4.7mm.....	78
• Gel formation time:	79
• Compression Strength Test	80
• Durability Test	84
• Water absorption test.....	84
• Resistivity test.....	86
Sao Paulo Metro Line 4 Tests.....	87
CHAPTER 5.....	90
CHOOSING THE BACKFILL GROUTING SYSTEM	90
• Compressive Strength.....	91

TUNNELLING WITH FULL FACE SHIELD MACHINES: Study of the backfill of the tail void

- Buoyancy and Set Time..... 91
- Pump System and Clogging..... 92
- Durability..... 93
- Bleeding and Segregation 96
- Economics 96

CHAPTER 6..... 97

NUMERICAL SIMULATION 97

1. Settlements induced by tunneling and excavation process..... 97
2. Empirical methods for subsidence estimation..... 100
3. Problem solving with computational methods 102
 - 3.1 Three-dimensional modelling of the backfill grouting 103
 - 3.2 Mesh and boundary conditions: 104
 - 3.3 Material properties..... 106
 - 3.4 Considered construction aspects and construction phases: 107
 - 3.5 Obtained results: 121

CONCLUSIONS 138

REFERENCES 141

PREFACE

The underground works have evolved in time; few years ago the excavation in soft ground was almost impossible. The invention of the Tunnel Boring machines, more specifically pressurized face ones, have permitted reaching new scopes and the utilisation of underground space in urban areas. Urban areas present critical conditions for tunnel excavation mainly due to the impact of the subsidence on the stability of buildings.

The face pressurized machines reduce the relief of the ground applying pressure against the excavation front, to guarantee the face stability. Moreover, while it is advancing, the permanent lining is installed, giving an immediate support to the ground.

The soft ground tunnelling has focused the settlement control in the optimisation of the face pressures. However within the years the interest about the ground settlements after the tail of the machine has arised. The tail void grouting is a procedure aimed to control the deformations after the passage of the TBM, injecting material between lining and ground to stop the relaxation and the insertion of the soil inside the tunnel

The available theoretical information about this phase in the tunnel construction is minimum. The behaviour of the tunnel after the lining assembling is uncertain, and the performance of the grout during the injection and till it hardens has not been extensively analyzed in technical literature.

The objective of this project is to study the grouting performance and its influence to the construction process.

To reach this objective the present project has studied the different aspects that characterize the performance of the backfill grouting, starting for the used materials to its application procedure. Also were included numerical and analytical models, to assess the behaviour of the grout during tunnel construction. These models made possible comparisons between different injection materials and other parameters regarding the injection process

CHAPTER 1

BACKFILL OF THE TAIL VOID

1. Definition

The use of the underground space has exponentially risen in the past few years with the Tunnel Boring Machines' technology development. The increase demanding together with new challenging projects requires new and more effective methods, particularly on the settlements field. During last years many efforts have been in order to minimize these settlements fields through the improvement of the stability of front. Today the annular gap injection is very important since it can influence the zero settlement process.

The annular gap is the open space between ground and lining after the TBM excavation and ring assembling. The backfill grouting is responsible of filling it with mortar. Frequently the cavity dimension goes from 150mm to 370mm, according to the width and shield tapering, route curve radius, the over-excavation (intentional, for better maneuverability, or involuntary), lining deformation, etc. (*Figure 1*)

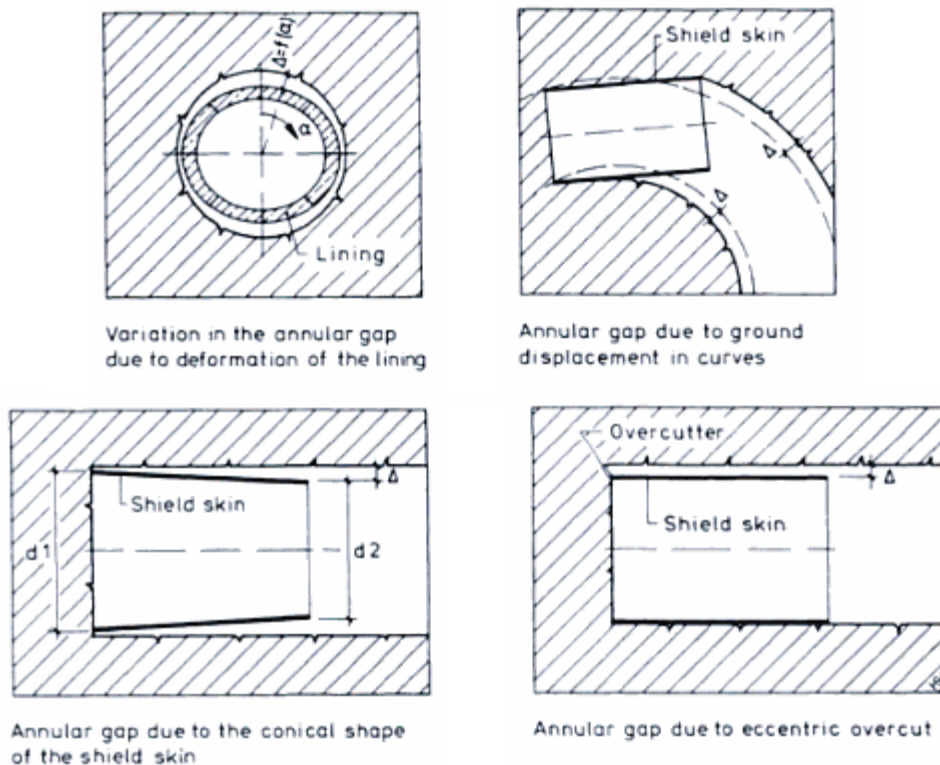

Figure 1 Tail void causes. (B.Maidl et al, 1995)

2. Objectives-Function

The main backfill grouting functions are: (Pelizza, 2009)(Guglielmetti et al 2007)

- reduce the surface settlements due to the entrance or deformation of the ground into the annular void. This opening space can reach the 16% of the total tunnel volume;
- create a uniform, homogenous and immediate link between ground and lining, providing the required resistance to distortion and the adequate loading to the rings;
- reduce the differential movements between segments, and avoid large bending moments;
- inhibit the movement of the tube during the TBM's progress, preventing the fracture of the segments or the gaskets;
- counterbalance buoyancy forces upon the lining;
- to resist the forces transmitted by the TBM back-up;

- to distribute homogeneously and symmetrically the stresses, avoiding the punctual loads;
- to complement the waterproofing system of the tunnel, mostly when the segments have been damage;
- to avoid the flow of water around the tunnel, especially toward the face;
- to contribute with the long term stability.

3. Types of Backfill Grouting

a. Used Methodology

The backfill practice can be done in two ways: after the passage of the machine, or simultaneously during the advancement. The selection of the methodology is based on the type of ground, its mechanical properties and the settlement control.

In case of hard soil or rock mass **radial injections** can be used, made through pre-existing holes in the concrete lining. The open spaces are furnished with screw connections and non return valves, in which is plug the pipe to inject the grout (*Figure 2*). This method is versatile because the tanks and pumps are movable, permitting to grout repeatedly if it is necessary. Moreover, they can be change easily in case the pipes are clogged.

Commonly after the primary grouting, some voids remain around of the tunnel, which should be grouted again, even twice (*Figure 2*). Voids can be caused by:

- settlement of the mortar;
- soil detachment due to high injection pressures
- wash-out of the grout in presence of large seepage pressure;
- leaking of the backfill;
- shrinkage of the mixture.

Defect points are usually identified by lining movements, unusual injection volumes or through in situ tests, but their dimension is normally unknown. Therefore, secondary grouting monitoring must be done carefully, in order to avoid pressure levels that can result in overstresses upon the lining support.

The major disadvantage of the radial grouting is that is carried out after the TBM has passed beyond the injection points in the segments. This delay, in addition with low self support time and water presence, might produce the collapse of the ground before the application of the backfill. The volume loss into the tunnel induces larger surface settlements. Also, the last ring remains unsupported for some time, compromising the security of the work.

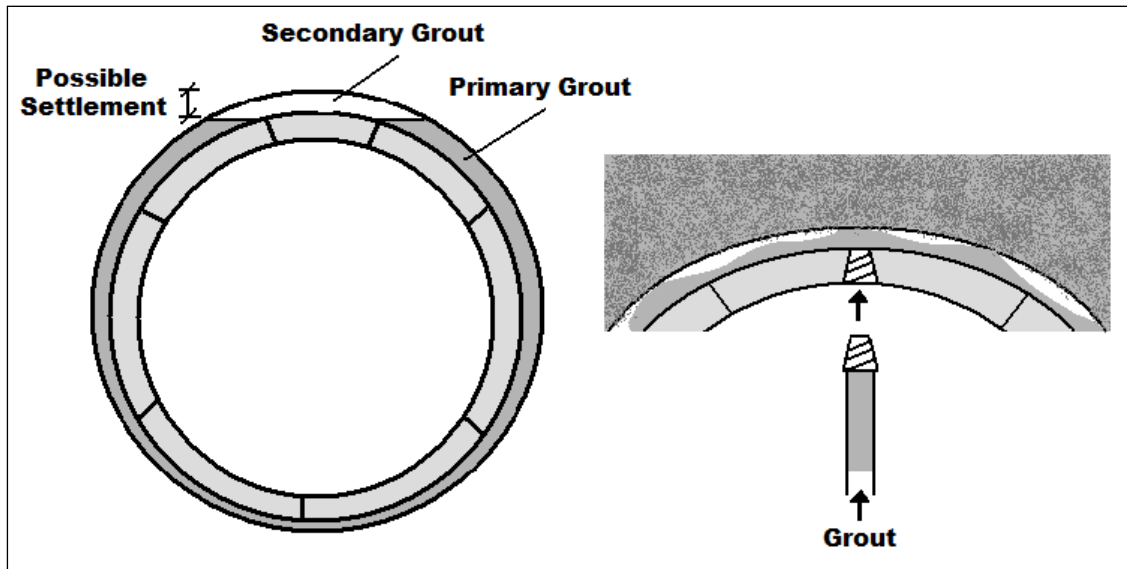

Figure 2 Radial Injections. Primary and Secondary Grouting

However, when the subsidence minimization is important or the tunnel is being constructed in soft soils, to employ the **simultaneous injection** method is widely recommended. In this technique, the backfilling is made automatically on the annular gap as soon as is created, reducing the unsupported time and counteracting ground movements (Figure 3). Nowadays the pressurized face machines, brings the grouting equipment integrated to them.

The application must be done at constant pressure, using an effective pump system, and has to be synchronized with the excavation velocity. This will control the stresses upon the ground and lining and for will maintain the tunnel excavation watertight.

The grout is injected through a series of pipes located at the tail skin. These are connected to one or more pumps situated at the TBM back up. The backfill is performed generally through 3÷8 nozzles, regularly distributed, for spread the mortar over the whole perimeter. With the aim to restrain the grout access into the excavation chamber, the tail skin is equipped with steel brushes, which are continuously supply with grease through a pipe system specially design for it. (Figure 4)

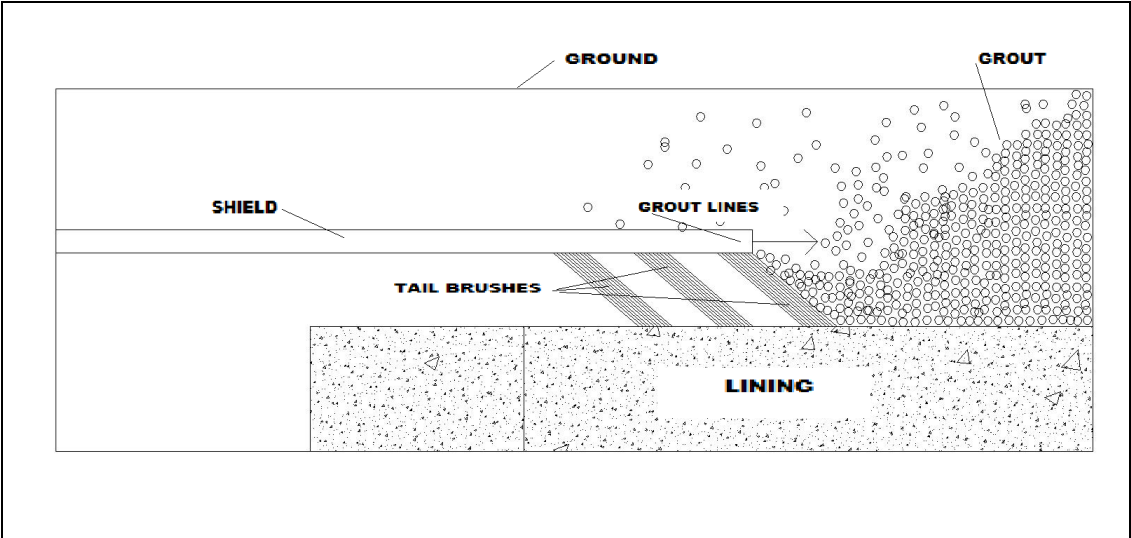

Figure 3 Simultaneous backfill scheme

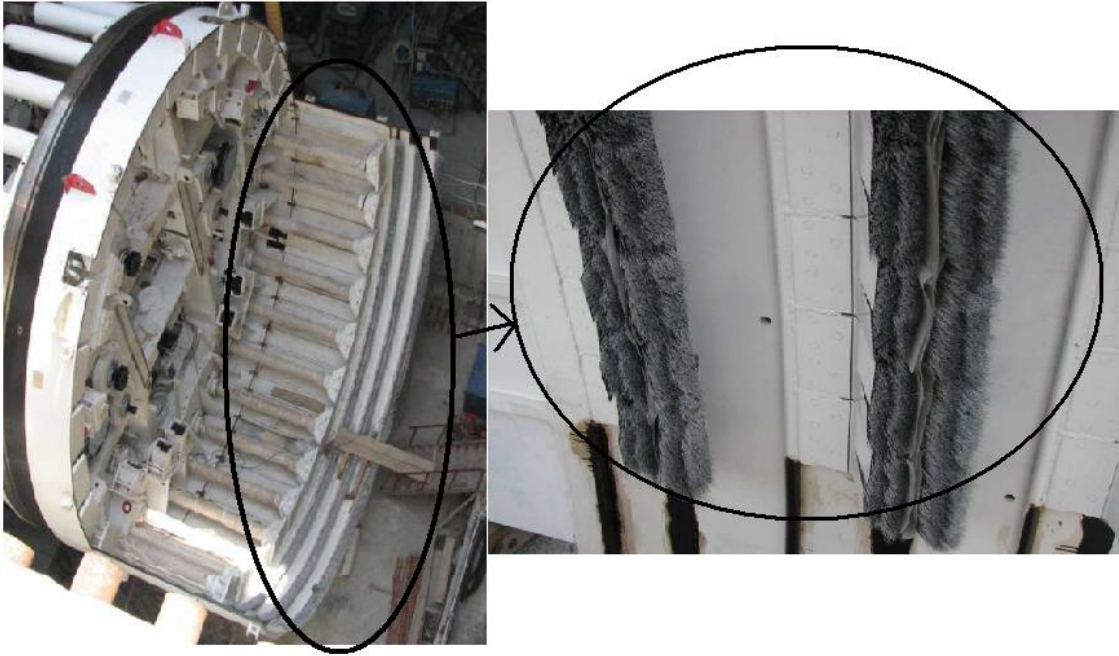

Figure 4 Disposition the tail brushes on the TBM shield (Dal Negro, 2009)

b. Used Materials

i. Inert (Cement-less Grout) and Semi-Inert Mix

The inert mixtures do not contain cement; instead of, it is replaced with fly ash or other substitutes. Additionally is also composed by water, a combination of sand and other materials as filler (*Table 1* and *Table 2*). The most frequent cement replacements are (Linger et al, 2008):

- pulverized fuel ash (PFA);
- hydraulic hydrated lime;
- limestone fillers (LF),
- other fillers produced by hard rock's crushing;
- micro silica (MS);
- metakaolin.

Often the cement-less mixes were applied only by radial injection through the segment holes, but currently they are also put in position using simultaneous backfill method. For its correct behavior the materials should have an appropriate grain distribution and shape. The selection of the aggregates should be accurate, avoiding anomalies both dimension and type. The grading curve of the semi-inert mix used in the Cairo Metro Line 2 is shown in *Table 3* (Shirlaw et al 2004)

<i>Typical Mix design of an INERT MORTAR</i>	
Coarse Sand	1300 kg
Fly Ash	600 kg
Bentonite	15 kg
Water	250 l

Table 1 Typical mix design of an Inert Mortar (Pelizza et al, 2008)

<i>Typical Mix design of a SEMI- INERT MORTAR (1m³)</i>		
Hydrated Lime	40	kg
Silica fume	60	kg
Inert Filler	595	kg
Rolled Sand	190	kg
Crushed Sand	470	kg
Water	470	litres

Table 2 Mix for 1m³ of grout, Phase 1 Cairo Metro Line 2 (Shirlaw et al, 2004)

Sieve Size (mm)	% passing
5	100
2.5	91
1.25	76
0.6	61
0.3	47
0.16	37
0.08	33

Table 3 Gradation of the inert mixture used in Cairo Metro Line 3 (Shirlaw et al, 2004)

ii. Pea Gravel

The pea gravel is constituted of granular material with grain dimension from 8 to 12mm. The compound should not have fines, in order to avoid obstructions of the injection lines. It is applied by means of radial pneumatic injections, using the same device to positioning the shotcrete.

This grout material is recommended for tunnels made in rock mass that can admit a tardy backfill and have small deformation rates. Also it is advised where the excavation front is not under pressure. In this situation the cement injections could not be convenient because the mortar might flow around the shield until the cutterhead leading to machine blockage.

The resistance of the pea gravel is low, but enough give stability to the lining. Obviously, the strength is not comparable with the efficiency of the cement based

mortars. In addition, this granular grout has a great rate of bleeding, allowing high volume losses and great deformability. However can be optimize with some content of cement paste or cement based suspensions injected after placing the gravel, especially at the bottom to increase the bedding. The advantage of this kind of material resides in its low costs.

The pea gravel injections are not suggested under the water table. The tunnel works as drainage and the gravel cannot counteract the flow of water, that can goes towards the face of the machine, or also leach the backfill material. This situation can be correct adding some cement paste to the mixture.

iii. Cement based Mortar

Also called active or semi-active grouts, this kind of mortars are composed of cement, water, aggregates, bentonite, and chemical additives (*Table 4*). Usually the amount of cement constituents goes from 50 to 200kg/m³ of mix. Cement controls the principle properties of the mix (setting time, the bleeding, costs and if would be necessary the use of additives).

Some cases will require, depending on the mortar expected properties and to the quality of materials locally available, the addition of retarder and plasticizer agents. However, the use of bentonite has shown its effectiveness, increasing the fluidity, especially on small diameter tubes.

The aggregates selection can determinate the shear strength, and the pumpability. Major proportion of crushed aggregates usually contributes with the short term resistance, but adding rounded ones helps the mortar workability. Therefore, it is good practice to mix 2 or 3 types of aggregates.

<i>Typical Mix design of a CEMENTITIOUS MORTAR</i>	
Cement	250 kg
Fly Ash	240 kg
Retarding Agent	2,5 l
Bentonite	55 kg
Water	733 l
Air	40 l

Table 4 Typical mix design of a Cement Mortar (Dal Negro, 2009)

iv. Two Components Backfill

The 2-components grout is made of two fluids, with the slurry consistency: the Component A (cement, clay or bentonite, water and retardant additive) and Component B (water and hardening additive, often sodium silicate) *Table 5*. These two components, liquid A and B, are mixed a moment before or while the injection is made. It is generated a gel, about 10 seconds after the combination, with thixotropic properties, capable of flow faster when is put under pressure. The material is able to fill uniformly the gap, because of its high fluidity, avoiding punctual loads, and according the permeability of the soil, can get into the surrounding ground. The composition of the mix makes it suitable for a large range of ground types and conditions. (*Figure 5*)

Practically, the component A is able to conserve the fluid state during approximately 72 hours, because of the action of the retardant additive. This is an important characteristic at the construction stage, since the occurrence of delays is common and because the storage excess of mortar is frequently needed in case of overcutting, or an enlargement of the opening caused for high injection pressures.

This type of grout was developed with the aim of guarantee a good workability in the transportation, storage and injection, but also a quick hardening. The gel state lasts about 30 minutes, after that begin the hardening. The strength development is normally near 100kPa after 1 hour.

The advantage of this method resides on the reduction of the risk of clogging, the quick creation of a gel that can fill all the voids and the rapidity of providing a foundation for the tunnel into few minutes after the injection, caused by its low hardening time. These properties allow a more effective injection process and in consequence a better control of the settlements.

<i>Typical Mix design of a TWO COMPONENT MORTAR</i>	
Cement	350 kg
Retarding Agent	5 l
Bentonite	35 kg
Water	796 l
Accelerator	61 l

Table 5 Typical mix design of a Two Component Mortar (Dal Negro, 2009)

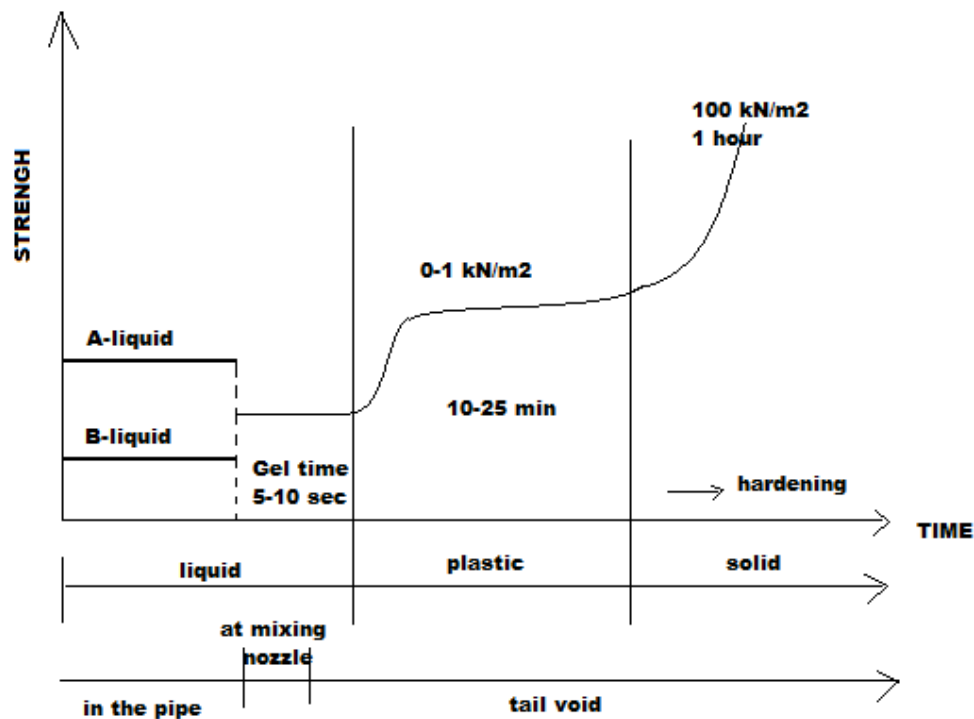

Figure 5 Strength development of the 2-components mix (TAC Corporation, 2009)

v. Deformable or Cellular Grout

Normally used in tunnels with high overburden pressure or tunnels in swelling rock, in which there is expected great deformation. This type of mortar allows working on those conditions where the employment of TBM's in combination with segmental lining was doubtful (*Figure 6*)

The early installation of the lining, with a high stiffness, in a highly deformable ground leads to excessive loading, economically inconvenient. Therefore, it has been studied the utilization of a compressible layer around the tunnel rings, using a cement mortar that is capable of change its volume and shape (*Figure 7*)

The features that proportionate the right behavior of the cellular grouts are: (Billing et al, 2007)

- low compression limit;
- improvement of the plastic behaviour;
- high maximal compressibility;
- maintenance of the initial elastic modulus until reaching the compression limit.

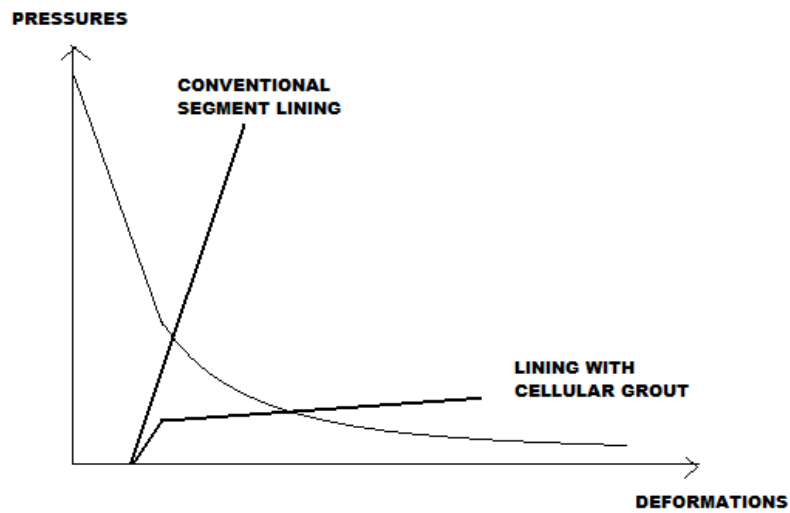

Figure 6 Correlation between pressure and deformation in the Cellular Grout (Billig et al, 2007)

These special grouts are made with super light aggregates (polystyrene pearls) and expansive clays, and allow the rock deformation without a considerable increment of the stresses upon the lining, obtaining lower pressures than with conventional grout.

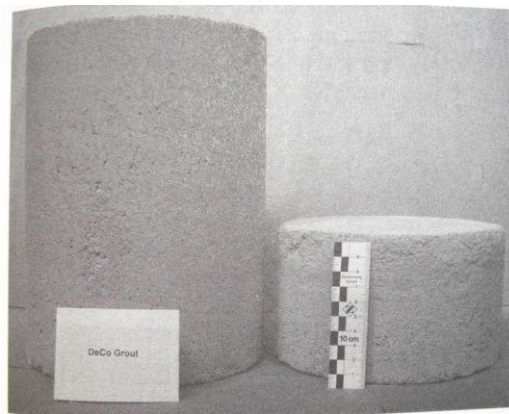

Figure 7 Initial state and final deformation of the cellular grout (Billig et al, 2007)

Finally, the *Table 6* offers a summary of the characteristics of every type of grout, their range of applicability, the injection system and the required equipment for its positioning.

TUNNELLING WITH FULL FACE SHIELD MACHINES: Study of the backfill of the tail void

Material	Application range		Backfilling system		Required Equipment				Specifics / remarks
	Hard rock	Soil	Grouting through grout holes in the lining segments	Grouting through the tailskin	Piston pump	Peristaltic pump	Progressive cavity pump	Pressurised air	
Mortar – active system	x	x	x	x	x				Conventional mortar, stiffness behaviour depends on using of additives
Mortar – reduced active system	x	x		x	x				Stiffness behaviour depends on using of additives
Mortar – inert system		x		x	x				Stiffness behaviour depends on using of additives
Two-component grout		x	x	x		(x)	x		Stiffness behaviour just after mixing
Deforming mortar	x		x	x			x		Only usable in hard rock (material under development)
Pea Gravel	x		x					x	Often used in hard rock, increasing of bedding by using mortar at the bottom, normally lower modulus of deformation and lower properties of embedment than for an active mortar

x = applicable

(x) = limited applicability

Table 6 Types of mortars and range of use. (Thewes et al, 2009)

4. Design Parameters of the backfill material. Ideal Features

Giving the principal functions of the backfill, the material should have some characteristics for the successful application, in economical and practical terms, and for the subsidence control:

- the backfill mortar must achieve good pumpability. This property allows a better application, without forcing the pumps, at great distance and reducing the risk of clogging;
- good workability and fluidity, during stocking and transport. Also in the short term permit a uniform and homogeneous distribution of the grout;
- not be affected by segregation, because this can compromise its durability, and the transmission of pressure to the lining;
- the grout should not be abrasive;
- must have short harden time and low permeability, for avoiding the volume changes, and for guarantee a correct support for the tunnel since early stages;
- the material cannot decompose after injection, because must conserve the confinement in short and long term. For 2-components grout, the water loss must be avoided, for achieved the needed durability. This is reached taking care of the bleeding levels and the change of volume caused by hardening. Usually impermeable soil or rock guarantees better durability;
- appropriated density and yield stress for counterbalance the buoyancy forces.

Every project will have its own particular necessities, which will be the base of the selection of the grout type, and the dosage, as can be seen in *Table 7*

TUNNELLING WITH FULL FACE SHIELD MACHINES: Study of the backfill of the tail void

Backfilling grouting, some examples of mix design

TUNNEL		EOLE	ST. PETERSBURG	PORTO	TORINO	BOLOGNA	CASTELLANZA	
REFERENCE		section 8.1	section 8.2	section 8.3	section 8.4	section 8.6	appendix 7	
COMPONENTS		No cement	Low cement content	Medium cement content	Medium cement content	High cement content	2-components	
							comp. A	comp. B
Cement	Kg/m ³	=	70	200	220	370	341	=
Water lime	Kg/m ³	=	=	60	=	=	=	=
Silica fume	Kg/m ³	=	40	=	=	=	=	=
Fly-Ash	Kg/m ³	400	300	120	380	=	=	=
Active Fly-Ash	Kg/m ³	200	=	=	=	=	=	=
Filler	Kg/m ³	=	=	=	=	580	=	=
Bentonite	Kg/m ³	40	=	=	=	=	43	=
Aggregates	Kg/m ³	(0-2 mm)	=	=	=	=	880	=
		(0-5 mm)	1000	1380	1530	=	=	=
		(0-6 mm)	=	=	=	1250	=	=
Water	l/m ³	250	260	230	250	270	812	=
Additives	%	plasticizer	4.1	2	4	3		
		retarder			0.1			
		air-entrainer					4	
		stabilizer						5
		jellying agent						4
		hardener						

Table 7 Examples of the utilization of the backfill grouting and its mix design (Guglielmetti et al, 2007)

5. Resistance Requirements

The employment conditions of the backfill consider less significant the long term behaviour than the immediate one. In the short term the material should have a suitable shear resistance for being able to transmit the earth and water pressure to the rings, besides of counter the buoyancy, the loads from the jacks, etc. Instead of, after some time, the lining will be the only responsible for sustaining the loads.

Actually, the backfill does not have structural function after some time, it only has to transmit the loads from ground to lining but not support them. Regarding the proper task of the mortars, they have to be avoided the cracks, but a fracture on the grout layer is not so likely under the confinement situation. Typically, the resistance required is about 0.1 to 1MPa.

Nevertheless, in special circumstances, as for example high overburden pressures, the mortar requires determined features. In this case the needed strength could go from 3 to 10MPa.

6. Theoretical Description. Rheology

The fluids normally present in nature are the so called Newtonian fluids. These fluids, as water, do not present any variation on the viscosity values subject to time variation, and consequently they do not resist shear stresses. Grouts are not in this category, because have a strong thixotropic behaviour, responding like a gel or paste at rest, and as a fluid when energy is exerted into it.

This means that mortars need a measurable shear stress to start the movement, that is identify as Yield Stress, or rigidity of the grout (*Figure 8*). Also grouts can change their viscosity in time, according to the flow conditions. This factor is important at the moment of fixing the injections pressures, and to establish its permissible range.

As well, the rigidity must be taken into account for providing an adequate initial pressure level to start the application of the grout. Moreover, the value of the yield stress will determinate the behaviour of the grout against the buoyancy when the mortar it is not hardened.

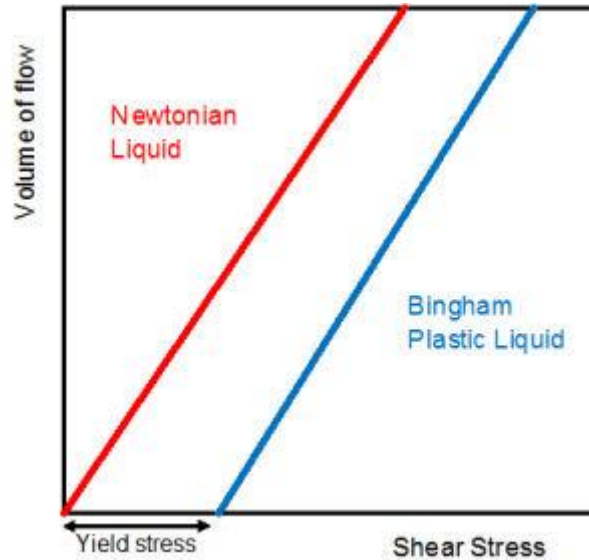

Figure 8 Rheological Behaviour of typical grouts (<http://en.wikipedia.org>)

The thixotropy can be described with the Bingham's Law:

$$\tau_{xz} = \tau_0 + n_B * \frac{dv_x}{dz}$$

where:

τ_{xz} = Shear stress needed to produce a relative velocity dv_x in x direction between two parallel plane layer distant a length dz.

τ_0 =yield value or cohesion or rigidity.

n_B =dynamic viscosity

Also may be expressed based on the apparent viscosity:

$$\tau_{xz} = n'_B * \frac{dv_x}{dz}$$

This apparent viscosity concerns both the dynamic viscosity and the rigidity. It depends of a reference velocity, because decrease with the increase of the flow velocity.

7. Backfill in Rocks

In rocks, the only way to connect the lining to the ground is through backfill grouting, because of the rock is no able to form a bond, at least without creating point loads or due to the detachment of blocks. Therefore, the backfill offer the right bedding for the tunnel, transmitting to the lining the loads of the ground, and maintain the rings without deformation.

The challenge in this type of procedure consists in:

- possible flow of the grout into the steering gap, that can lead to clogging of the opening. If the mortar hardens in this space, there will be needed high jacking forces to continue the advance;
- erosion of the material at the tail void before it hardens. To his matter, it will be required a high strength since early stages (*Figure 9*).

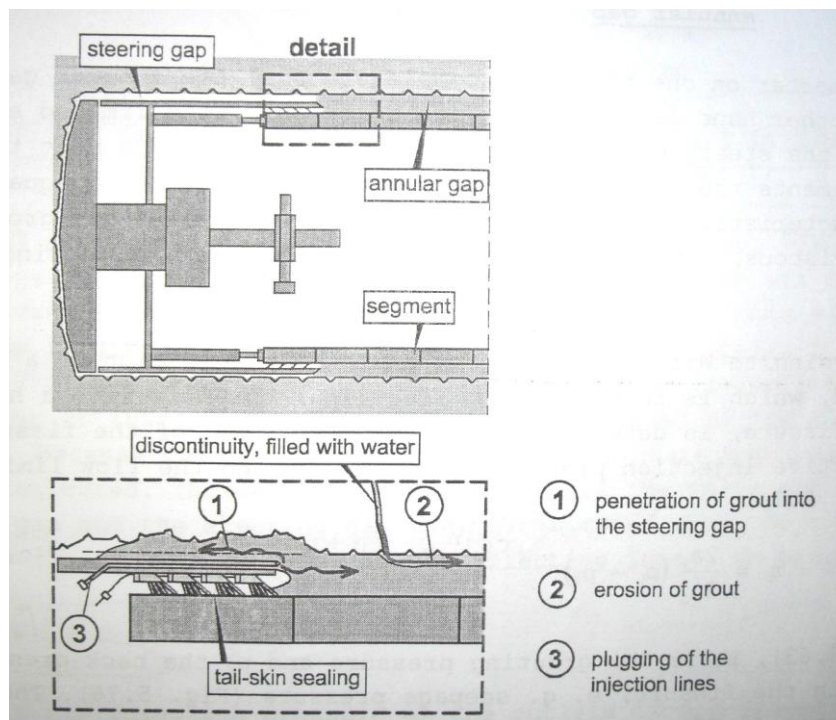

Figure 9 Challenges of the backfill in Rock (Wittke, 2007)

8. Control of the backfill process

Because of the uncertainties of the tunnel process, and the different geological conditions that can be found, the monitoring practice is of major importance. Modern tunnel machines are equipped with programmable logic controllers and data-loggers, which transmit the information to the operator via a visual screen display while the excavation is conducted, and register the data in paper. The analysis of this data has to be done carefully, for the last 5 rings, searching for any anomaly. Every monitored parameter is associated with a reference value with an admissible deviation and the corresponding alerts or alarms. The backfill process is supervised carrying out the following methods:

- Control of grout volumes

The calculation of the theoretical annular void volume must be correlated with the volume of grout injected, in relation with the TBM advance. The void is calculated as the volume of the total excavation minus the volume within the lining limit, evaluated on a ring length.

$$V_{void} = \left(\frac{D_{EXC}^2}{4} * \pi - \frac{D_{LIN}^2}{4} * \pi \right) * L_{RING}$$

where:

V_{void} : Volume of the void

D_{EXC} : Diameter of the excavation section

D_{LIN} : Diameter of the lined section

L_{RING} : Length of the ring (parallel to the tunnel axis)

The quantity of grout injected can be affected by the permeability of the soil, the advance rate and route, and the waste of the cutters; therefore the theoretical volume and the grout volume could be different. Generally the volume injected is about 120-130% of the found in calculations, and it is recommended that the grout stocking tank has at least double the theoretical grout requirement for each ring of tunnel advance, to enable the filling of any over-break as it occurs (Telford, 2005). Nevertheless significantly variance of the amount of grout can represent an over-excavation or a leak of grout towards a pre-existing cavity.

- Control of backfill pressures

The grout pressure must be set in design stage, correlated with the face, earth and water pressure. Knowing the advancement rate, the pressure should be verified during the excavation and compared with the previously established amounts.

Low grout pressures could allow the collapse of the surrounding soil, leading to subsidence. However, extremely high grout pressures can lead to local yielding for the soil at the crown level, causing surface settlements as well.

Nowadays are used automatic monitoring pressure systems that have set up the pressure value for each nozzle position. These instruments are connect to the injection valves and, once is arrived to the design pressure the backfill grouting is stopped. Preventing incorrect operation, are equipped with safety valves in case of excessive pressures.

- Checking the mortar characteristics.

It is advised testing the grout before it is used. There is not a normative for regulate the trials, but some of the most used are reported in Chapter 4.

CHAPTER 2

INJECTION PRESSURES

The injection pressure is chosen generally based on the face pressure, the overburden load at the crown and the water pressure. The grouting pressure does not have a standard accepted value; the range of application is empiric, varying case to case. Some research has resulted in the following pressure values:

- the total overburden stress on the crown; (Wittke, 2007)
- the total water pressure, for rock mass with good mechanical properties (Hashimoto et al, 2009)
- total overburden load plus 0,5 to 1 bar; (Biosca et al, 2008)
- the face pressure applied for the EPB machine, plus 0.5 bar; (Peila, 2010 personal information)
- 1,5 to 1,8 times the face pressure. (Ramirez, 2010, personal information)

Probably every design and construction company has its own established values recovered from their experience, but there were not found theoretical values on technical literature. The discussion initiates, what is the better range for the injection pressures.

The pressure has to fulfil different conditions:

- being large enough for reaching the smallest volume loose as possible;
- being small enough for avoiding over loading of the lining and uplift of the ground, as consequence of over pressure into the annular void;
- being sufficiently low for prevent entry of grout into the steering gap, and subsequently into the excavation face;
- being an adequate amount to avoid local damage of the segmental ring, for example the movement of the key-segment. (*Figure 10*)



Figure 10 Key segment forced out of position (Dal Negro, 2006)

The tail void injections are conditioned by the type of soil, its self support time and density. In case of loose soil, greater pressures might be required, for pushing the ground towards its initial place. Actually, the injection pressures are estimated in design phase but are definitively decided through the observation in situ, as the tunnel excavation advance and supported by monitoring values. It is important to consider that the measures are taken inside the TBM, and the exact value at the injection point is not the same; normally is slightly lower because of the losses produced along the pipe.

Theoretically the pressure determination is uncertain in many ways, but some parameters have been analyzed in the past decades.

1. Backfill in presence of seepage water. Erosion of the grout in the annular gap

The presence of ground water can be a significant problem in rock excavations, mostly in joint rock, which discontinuities and fault zones will drain the water. For counteracting the water, the backfill grouting must maintain the pressures for long time, and the grout properties should confront the erosion. When the water flow is too high, even if the mortar is resistant and the injection rate is elevated, it occurs a buffering of the pipe, making the process unsustainable. As a result, when is expected high water table, the most convenient proceeding is to pre-treat the ground, thus sealing the joints.

Also the erosion should be avoided. It was designed a simple model, to characterize the erosion situation on the annular gap (Wittke, 2007). It is assumed that the water comes to the tunnel through a discontinuity of width $2a_i$. The internal friction between the grains of the mortar is neglected, and the shear strength is given by the yield stress of the grout.

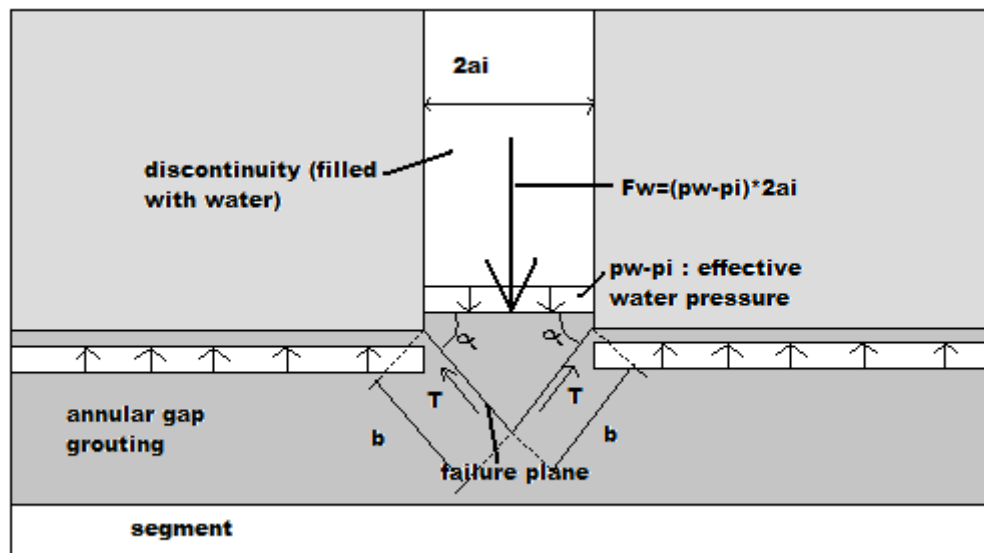

Figure 11 Erosion situation model. (Wittke, 2007).

The water only can get into the tail void if its pressure (p_w) is greater than the injection pressure (p_i); and the erosion of the grout will occur if the effective water pressure ($p_w - p_i$) is higher than the shear strength of the mortar. Based on the (Figure 11) the condition can be written as follows:

$$F_w - 2 * T * \sin \alpha > 0$$

Where:

$$F_w = (p_w - p_i) * 2a_i$$

$$T = \tau_0 * b$$

If is chosen the Mohr-Coulomb Criteria and is made a geometrical relation, it is found:

$$\alpha = 45^\circ + \frac{\varphi}{2}$$

$$(2ai)^2 = 2 * b^2$$

$$pw - pi > \tau_0 \quad \rightarrow \quad pi = pw - \tau_0$$

In this way it is obtained the minimum injection pressure for avoiding the leach of the backfilling.

2. Penetration of the grout

The overcutting is a practice that allows the manoeuvrability of the TBM, for curve alignments for example. Also, the shield of the machines are made with certain tapering, having greater diameter at the face than at the tail. Normally the decrease is about 4% of the diameter in the front.

The penetration of the grout is governed by the mortar characteristics. The grout must have a good fluidity in the application moment, filling completely the annular void. An excessive introduction pressure may divert the trajectory of the substance pushing the grout into the steering gap, which is the opening between shield and excavated soil, arriving even into the excavation face, incrementing the risk of clogging the machine.

According to Wittke (1969), the depth of penetration of a Bingham fluid, which is injected from a vertical borehole into a horizontal fissure, is determined for the equation:

$$rf = \frac{2ai}{2\tau_0} (pi - pw)$$

where:

rf : depth of penetration of a Bingham fluid;

$2ai$: aperture of the annular gap;

$(pi - pw)$: effective injection pressure, with pi , the injection pressure, and pw , the water pressure;

τ_0 : yield stress of the Bingham liquid.

With this formula is possible to estimate the penetration of the mortar both annular gap and steering gap, when the injection is effectuated by means of radial injections through holes in the segments. (*Figure 12*)

This relationship is been verified and validated several times on cement suspension and pastes with different composition. (Wittke, 1969; Wallner, 1976; Wittke et al.,1978; Wittke and Breder, 1984; Heil and Wittke, 1986) (Wittke, 2007)

On the other hand, when the backfill is done simultaneously, the situation is different, because the injections are parallel to the axis of the tunnel.

The instant when the backfill grouting is almost complete and a surplus is being pump is the less advantage condition for the studied penetration problem.

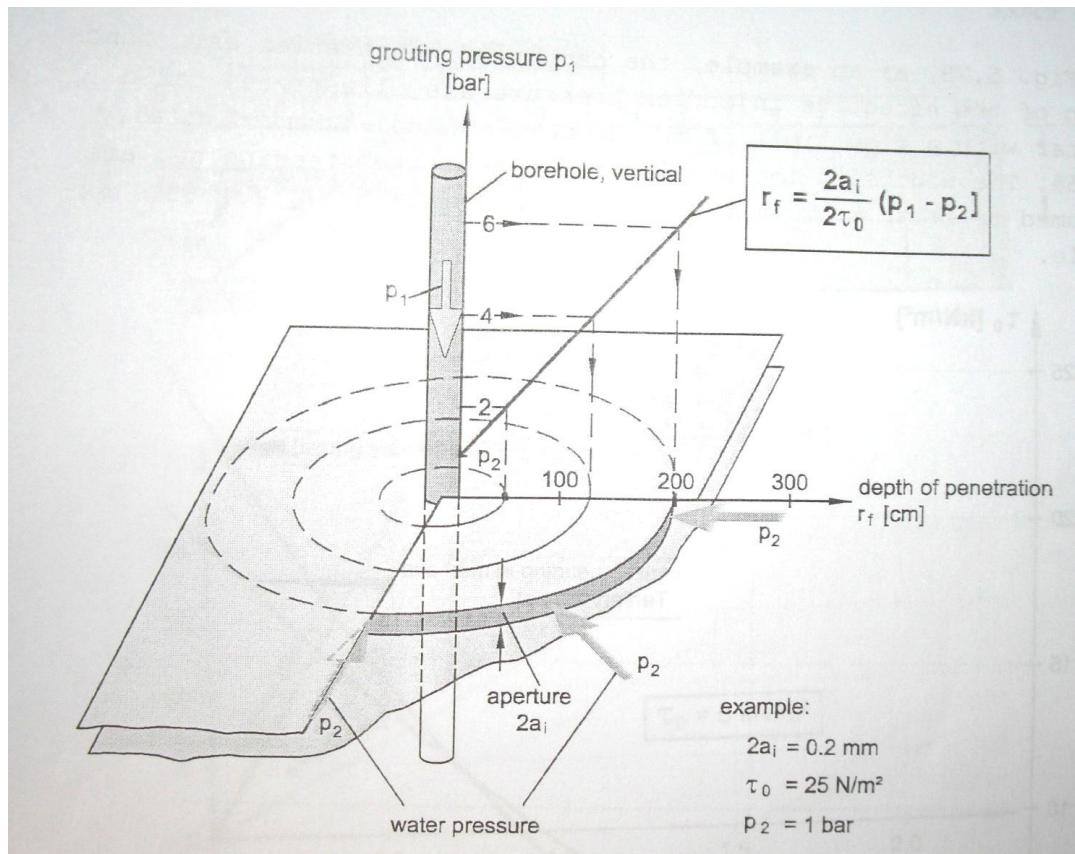

Figure 12. Penetration model of radial backfill injections (Wittke, 2007)

When the annular gap is full, the grout generates a hydrostatic pressure against all the adjacent parts around it. This pressure is counteracted by the grout of the previous ring, the current lining ring, the soil, the sealing brushes, etc. But it can find a free surface or gap, the steering gap around the shield. The access to this space is impeded for the shear forces of ground and shield, and for the soil obstruction as a result of the ground relaxation and soil loosening. With this opposition the grout will move only if the pressure is such that to create a shear force higher than the yield stress.

On Bingham fluids the viscosity and the yield stress rule the movement of the fluid. The viscosity controls the velocities and shear rate, while the yield stress regulates the initial movement. For this case, the velocities are so low that the problem can be focused in the limit static moment; the analysis regards the

instant when the grout initiates the dynamic behaviour, and the viscosity can be neglected.

Recently an experimental model is been developed for the qualitative evaluation of the grout inclusion around the shield zone (Bezuijen et al; 2007). The model assumptions are:

- a linear elastic soil, with a shear modulus G ;
- neglecting the influence of the gravity, presuming the tunnel is positioned perfectly symmetric in the bore hole,
- the soil is in contact with the shield at the face. The tapering aperture origin a pressure decrease of the tensional state of the surrounding soil and the stress diminish from the face to the tail.

When the grout pressure is higher than the earth pressure, the soil tends to compress toward the walls of the tunnel, and the grout can advance. The compression generates a new steering gap dimension that can be calculated as follows: (Verruijt, 1993)

$$\Delta\sigma = 2 \frac{\Delta r}{r} G$$

where:

$\Delta\sigma$: change in pressure of the surrounding soil;

Δr : change in the tunnel radius as consequence of the new steering gap dimension;

r : radius of the tunnel and the grout;

G : shear modulus of the soil around the tunnel.

The deformation will be the one created for the difference of pressure between ground and grout, and the total dimension of the steering gap will be the original value, as consequence of the overcutting and tapering, plus the deformation.

The opening walls create a friction in the grout which counteracts the advancement pressure, the smaller the steering gap the higher the pressure losses in the fluid. For describing these decreasing, it can be assumed that the major friction is found between the grout and the soil, so it can be neglected the interaction with the shield. Known the yield stress value and the width of the gap can be estimated the pressure losses.

$$\Delta P = \frac{\Delta x}{s} \tau_y$$

Where ΔP is the change in pressure due to friction, Δx a length interval of the TBM shield, s the joint width between the tunnel and the soil and τ_g the shear stress of the grout around the machine.

Using this approach it is possible to estimate the maximum pressure which makes the grout reach the pressure chamber, the dimension of the joint, and the length of the grout flow.

Also, during the utilization of Slurry Shield machines, the bentonite showed the same behaviour. Therefore the study must be done with the bentonite as well. The grout flows from the back to the face and the bentonite from the face to the tail, joining each other in some point. To the previous method is added a difficulty: the direction of the flow is important, and the different options should be analyzed.

It must be highlighted that this approach is only qualitative, because is based on assumptions that are not actually close to reality. Furthermore, the vertical loads and the effect of the hydraulic jacks are not considered either. For a quantitative result it is necessary the use of more sophisticated numerical models. Based on the previous method, it can be study the penetration of the grout problem into the three dimensional scope. It is considered the same principle and it is assumed a symmetric, uniform pressure into the annular gap. The injection pressure can be confronted with the radial ground stress obtaining the distance that can reach the grout all around the TBM shield. The studied approach uses the characteristic curve for estimation of the displacements. The utilisation of this tool makes possible to have a relationship between ground pressure variations from the start of the excavation until the equilibrium of the deformations with the effect of the plasticisation of the soil, which was not considered until now.

The soil, grout, shield and lining parameters are found in the *Table 8* to *Table 12*, as well as the geometry employed in the example.

Soil Parameters		
Specific Weight	γ (KN/m ³)	19,00

Cohesion	C' (kPa)	4,00
Friction Angle	ψ (°)	30,00
Young's Modulus	E (MPa)	400,00
Poisson Coeficient	ν	0,30
Pore Pressure	Pw (kPa)	50,00
Shear Modulus	G(MPa)	154
Bulk Modulus	K(MPa)	333

Table 8 Soil Parameters

Lining Parameters		
Young's modulus	E (MPa)	37000,00
Poisson Coeficient	ν	0,23
Specific Weight	γ (kN/m ³)	24,000
Width	hl(m)	0,40
Inner Radius	Rli(m)	4,53
Outer Radius	Rlo(m)	4,93

Table 9 Lining Parameters

Grout Parameters		
Young's modulus	E (MPa)	8000,00
Poisson Coeficient	ν	0,20
Specific Weight	γ (kN/m ³)	24,000
Width	hg(m)	0,07
Injection Pressure	Pi(kPa)	289,60
Yield Stress	τ_y (kPa)	1,60
Shear Modulus	G(MPa)	3333,33
Bulk Modulus	K(MPa)	4444,44

Table 10 Grout Parameters

Shield Parameters		
Young's modulus	E (MPa)	210000,00
Poisson Coeficient	ν	0,30
Specific Weight	γ (kN/m ³)	78,00

Width	hs(m)	0,05
Inner Radius	Rsi(m)	4,93
Outer Radius	Rso(m)	4,98
Length	L(m)	5,00
Over cutting	so(m)	0,02

Table 11 Shield Parameters

Tunnel Geometry		
Overburden	H (m)	40,00
Diameter	D (m)	10,00
Radius	R(m)	5,00

Table 12 Tunnel Geometry

The calculation steps development is presented in the following part:

- to calculate the Terzaghi's ground load.

$$P_v = \frac{B * \left(\gamma - \frac{2c}{B} \right)}{\tan \varphi} \left(1 - e^{-\frac{2H \tan \varphi}{B}} \right)$$

- to divide the tunnel transversal section in 15° segments.
- to estimate the radial pressure transmitted to the ground for each segment, calculating the impact of the grout pressure, the lining and grout weight. The grout pressure is assumed symmetric and uniform, and the lining and grout weight only affect the bottom part of the tunnel. (Figure 13)
- to calculate the characteristic curve using the following equations (Pelizza et al. 2009). A first method it can be used the level of relaxation that leads to the deformation close to the overcutting. (Figure 14)

$$P_{cr} = P_o * (1 - \sin \varphi) - c * \cos \varphi$$

$$N = \frac{1 + \sin \varphi}{1 - \sin \varphi}$$

$$u_e = \frac{1 + \nu}{E} * (P_o - P_{cr}) * R_{int}$$

$$R_{pl} = a \cdot \left[\frac{(p_0 + c_R \cdot \cot g\phi_R) - (p_0 + c_P \cdot \cot g\phi_P) \cdot \text{sen}\phi_P}{p_i + c_R \cdot \cot g\phi_R} \right]^{\frac{1}{N_R - 1}}$$

$$u_r = \frac{1 + \nu}{E} \cdot \left\{ \begin{aligned} & \frac{R_{pl}^{k+1}}{r^k} \cdot (p_0 + c_P \cdot \cot g\phi_P) \cdot \text{sen}\phi_P + (1 - 2\nu) \cdot (p_0 + c_R \cdot \cot g\phi_R) \cdot \left(\frac{R_{pl}^{k+1}}{r^k} - r \right) + \\ & - \frac{(p_i + c_R \cdot \cot g\phi_R) \cdot [1 + N_r \cdot k - \nu \cdot (k + 1) \cdot (1 + N_r)]}{(N_r + k) \cdot a^{N_r - 1}} \cdot \left[\frac{R_{pl}^{N_r + k}}{r^k} - r^{N_r} \right] \end{aligned} \right\}$$

A second approach could be to assume the front arrives when 30% of relaxation is reached, inserting the shield as a support curve. The support would absorb the ground load gradually from the insertion point until a certain deformation (equilibrium), when it would find the soil convergence curve. This method does not consider the overcutting or the tapering, but are taken into account the displacements before the front, and the process of loading the shield. In the present example the first method is used.

- for simplicity it was assumed the tensional state and the injection pressure as uniform for all the tunnel section.
- the soil behaviour is formulated as ideal elastic-plastic, so the ground will have the same elastic modulus for loading that for unloading; the elastic deformations can turn back, whilst the plastic deformations will remain.

The ground is deformed as consequence of the stress relief. The displacement at the tail is caused by the unloading, having an elastic component and a plastic component. When the grout injected push the soil towards its initial position, the soil is reloading keeping the plastic deformations. However, the elastic displacement will turn back following the same trajectory for unloading.

Therefore, the reload curve is determined, as a parallel straight line to the elastic unloading and starting from the overcutting displacement. The soil into the steering gap will deform following that trend. (*Figure 14*)

- the calculation consists in dividing the shield length in equal segments and makes the pressure analysis showed in *Figure 16* for every section.

The shield is divided in segments of 0.2m for the preliminary study. To obtain greater precision these segments can be reduced to 0.10m.

When the grout pressure is higher than the earth and water pressure the soil is compressed, turning back the precedent deformations. It is calculated the

difference between grout, earth and water pressure. If the result is positive the value is evaluated on the reloading curve, obtaining the hypothetical convergence, which divided by 2, result in the new deformation amount.

The total deformation of the opening is determined by the sum of the overcutting value in that position and deformation created by the injection.

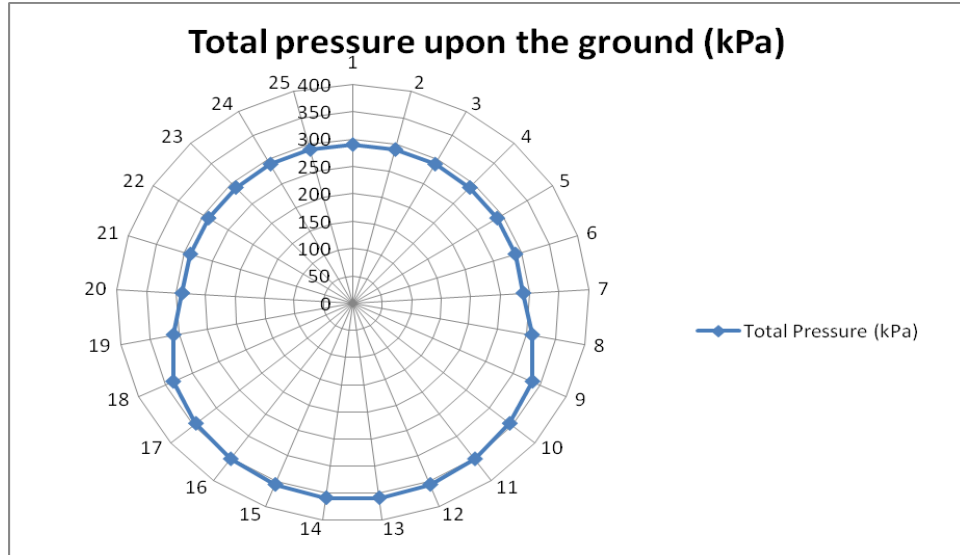

Figure 13 Total Pressure acting upon the ground

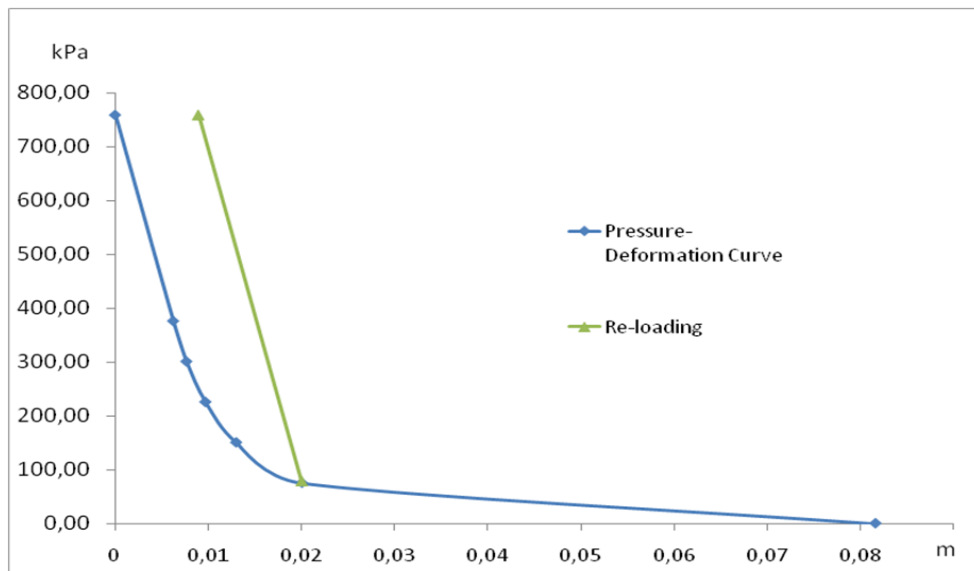

Figure 14 Characteristic curve and Re-loading Curve

With the new size of the gap, the pressure loss is calculated, using the formula proposed by Bezuijen et al, (2007).

$$\Delta P = \frac{\Delta x}{s} \tau_{\gamma}$$

The pressure losses are subtracted to the current pressure amount and the process initiate again, for the second segment of the shield, and so on.

- there are tested different situations:
 - overcutting of 2cm and ground deformation of half that value (1cm):
 - eccentricity of the gap due to lowering of the shield induced by self weight. (Gravity considered);
 - no gravity action, instead, uniform overcutting of 2cm around all the cross section is assumed, and relaxation of 1cm. The TBM is simulated as floating in the tunnel cavity;
 - relaxation equal to the total overcutting for all the tunnel section, in attempt to understand the behaviour of the system when tunnelling in very poor soils.

For every situation previously mentioned was examined a low pressure value (80kPa), a normal pressure value (300kPa) and a high grout pressure value (800kPa), based in the technical literature data.

- for the eccentricity case the extension of the gap was determined graphically for every segment of 15°. (*Figure 15*)

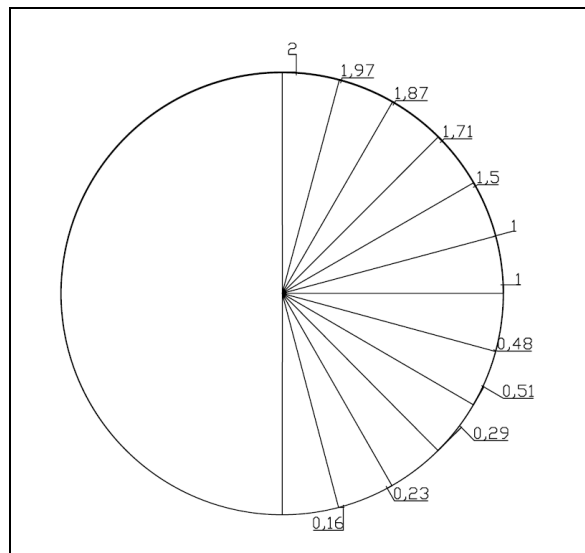

Figure 15 Tunnel eccentricities around the cross section

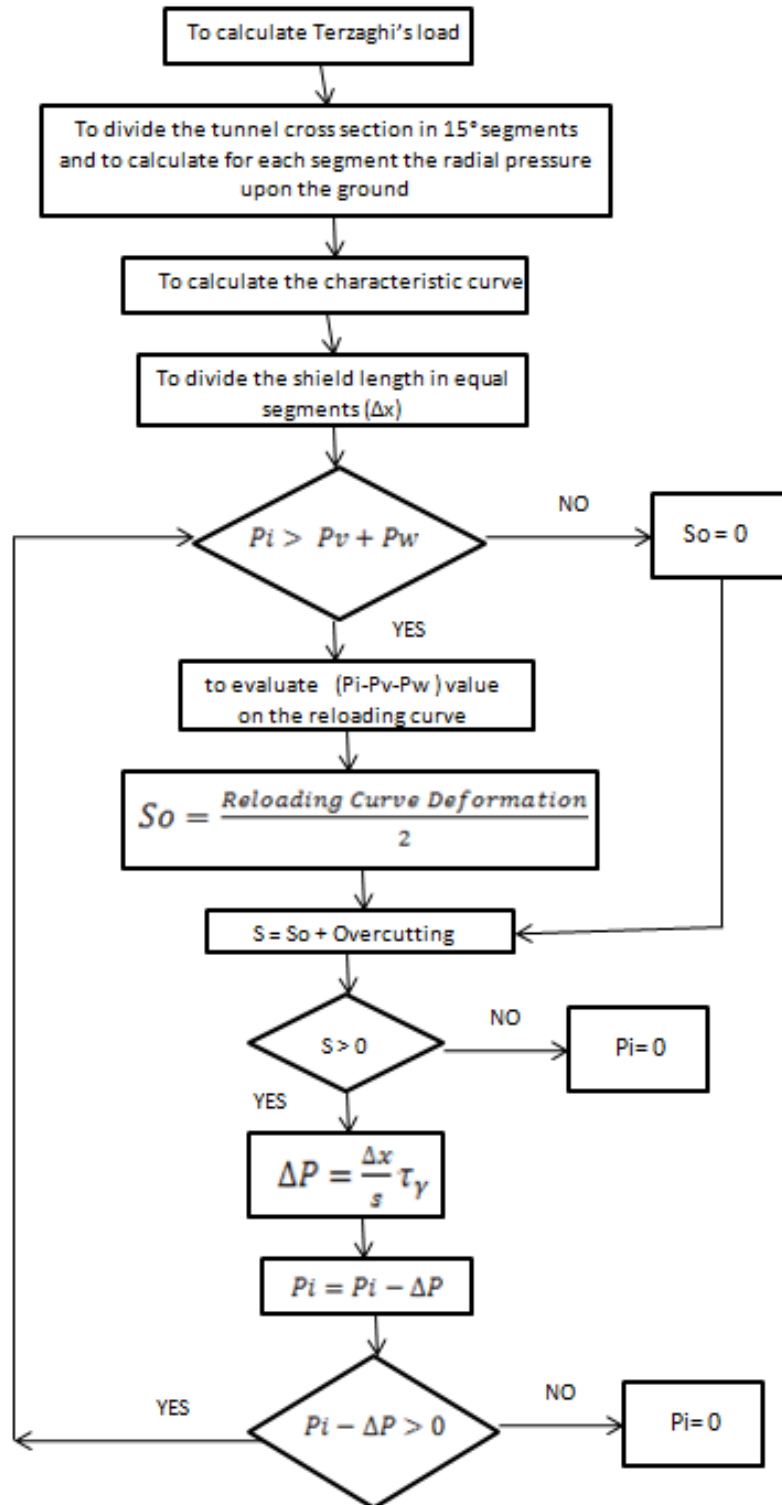

Figure 16 Procedure of the grout penetration analysis

Obtained results:

The cases when the eccentricity is considered are quite close to reality. The self weight of the TBM head push downward the shield and shut the steering gap, duplicating the space in the upper part. The penetration lengths found for these cases are reported in *Table 13*, and *Figure 17*, *Figure 18* and *Figure 19*.

300 kPa		800 KPa		80 Kpa	
$\theta(^{\circ})$	DIST FROM THE TAIL (m)	$\theta(^{\circ})$	DIST FROM THE TAIL (m)	$\theta(^{\circ})$	DIST FROM THE TAIL (m)
0	3,60	0	5,00	0	0,90
30	3,40	30	5,00	30	0,90
45	3,00	45	5,00	45	0,80
60	2,60	60	5,00	60	0,70
90	1,80	90	5,00	90	0,40
120	1,00	120	3,60	120	0,50
135	0,60	135	2,60	135	0,30
150	0,40	150	2,40	150	0,20
180	0,20	180	1,40	180	0,00

Table 13 Penetration length for eccentric case

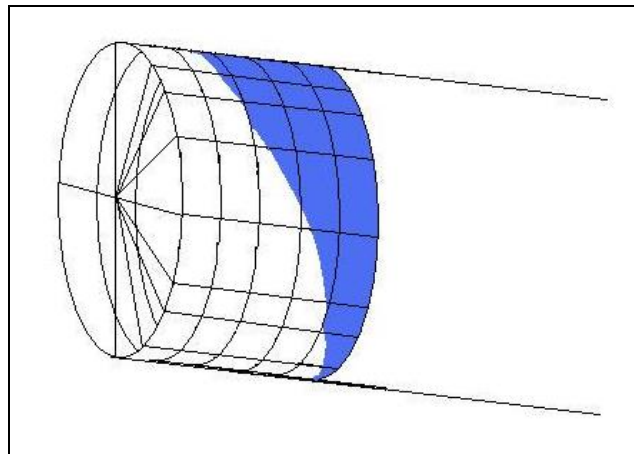

Figure 17 Penetration length, eccentric case, 300kPa

For all pressures proved, it can be observed that the grout tends to entry widely into the superior part of the tunnel; this is consequence of the greater space to flow which, additionally, generates less friction and smaller pressure drop. It is remarkable the large difference between the arrived distances in the top and the bottom for the 300KPa case: at the upper part is reached a high distance, and in the bottom only a few centimetres. This leads to the necessity of

accurate control of the pressure and volumes, because if a considerable overcutting is made, the grout can easily arrive to the front.

As expected the higher the pressure, the larger the scope of the fluid.

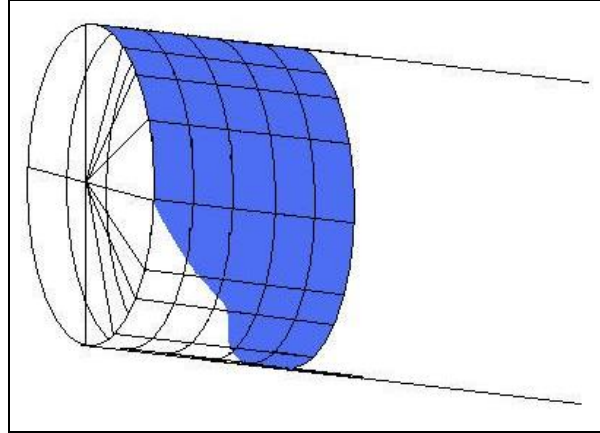

Figure 18 Penetration length, eccentric case 800kPa

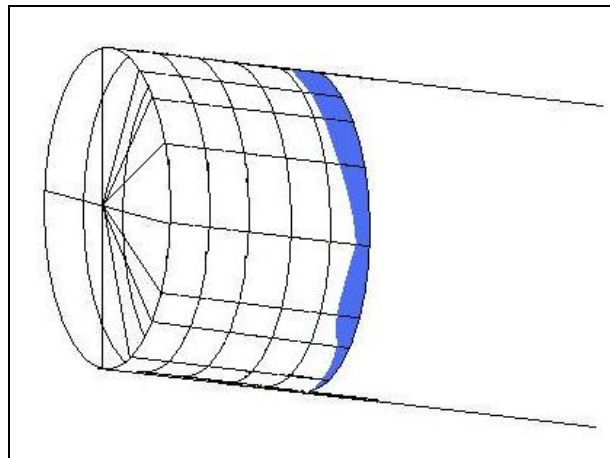

Figure 19 Penetration length, eccentric case 80kPa

The case in which the TBM was considered without eccentricity is not close to reality, although it is useful for studying the pressure influence, higher in

the bottom and lower in the top as usually is in situ. Normally are needed higher pressures in the base than in the crown to content the larger stresses there. (Table 14)

300kPa		600kPa		80kPa	
$\theta(^{\circ})$	DIST FROM THE TAIL (m)	$\theta(^{\circ})$	DIST FROM THE TAIL (m)	$\theta(^{\circ})$	DIST FROM THE TAIL (m)
0	1,80	0	4,40	0	0,40
30	1,80	30	4,40	30	0,40
45	1,80	45	4,40	45	0,40
60	1,80	60	4,40	60	0,40
90	1,80	90	4,40	90	0,40
120	2,10	120	4,80	120	1,00
135	2,20	135	5,00	135	1,10
150	2,20	150	5,00	150	1,10
180	2,30	180	5,00	180	1,10

Table 14 Penetration length, non eccentric case

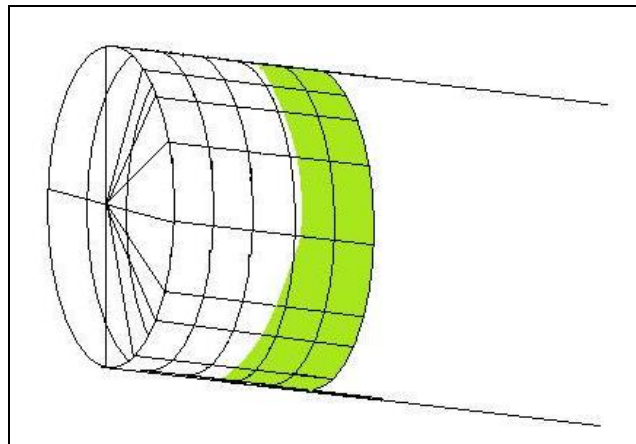

Figure 20 Penetration length for no eccentric case 300kPa

The Figure 20, Figure 21 and Figure 22 show that the ground tends to fluid into the inferior part, due to the gravity force and the greater pressures in the bottom, although the difference between these lengths is not as elevated as for

the eccentric cases. This demonstrates that the restrictive value of the penetration mechanism is the width of the cavity beyond of the pressure range.

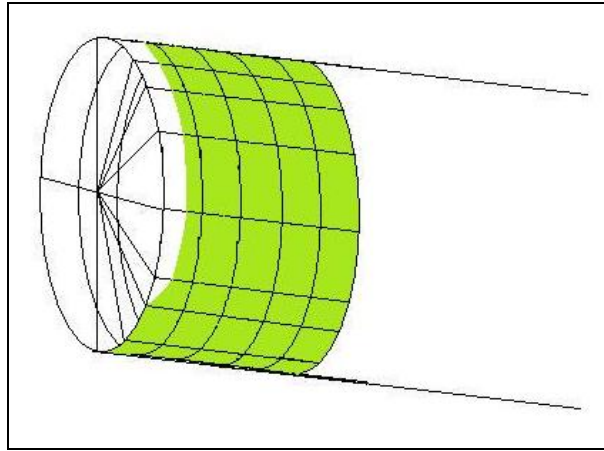

Figure 21 Penetration length, no eccentric case, 600kPa

For the case of no eccentricity, it is enough a 600kPa pressure for the grout arriving to the excavation face at the bottom, and slightly higher pressure also at the upper part. (*Figure 21*)

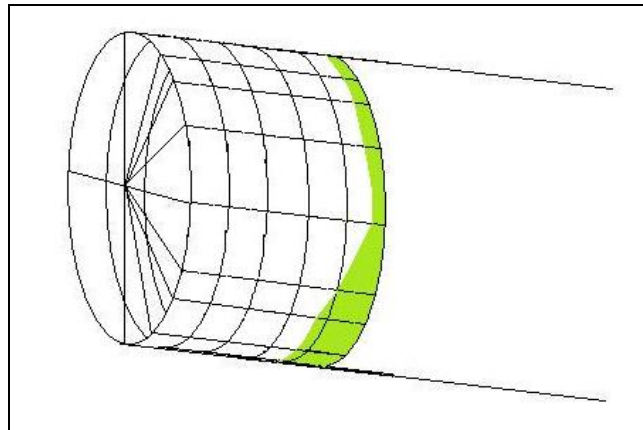

Figure 22 Penetration length, no eccentric case, 80kPa

Perhaps the most realistic approach is which regard the soft soils, for null steering gap. Although the values found (*Table 15*) represents that is unlikely the grout arrive to the face, it is worthy make the verification of the influence of different kinds of soils and relaxation rates.

300 kPa		800 kPa		250 kPa	
$\theta(^{\circ})$	DIST FROM THE TAIL (m)	$\theta(^{\circ})$	DIST FROM THE TAIL (m)	$\theta(^{\circ})$	DISTFROM THE TAIL (m)
0	0,10	0	1,00	0	0,05
30	0,10	30	1,00	30	0,05
45	0,10	45	1,00	45	0,05
60	0,10	60	1,00	60	0,05
90	0,10	90	1,00	90	0,05
120	0,10	120	1,20	120	0,05
135	0,10	135	1,20	135	0,05
150	0,10	150	1,20	150	0,05
180	0,10	180	1,20	180	0,05

Table 15 Penetration length no steering gap case

This approach underlines that the scoped length around the shield machine is influence by the pressure, independently of the size of the steering gap (*Figure 23 to Figure 25*). The results illustrate that are needed much higher pressures than the suggested values for shallow tunnels to arrive up to the excavation face.

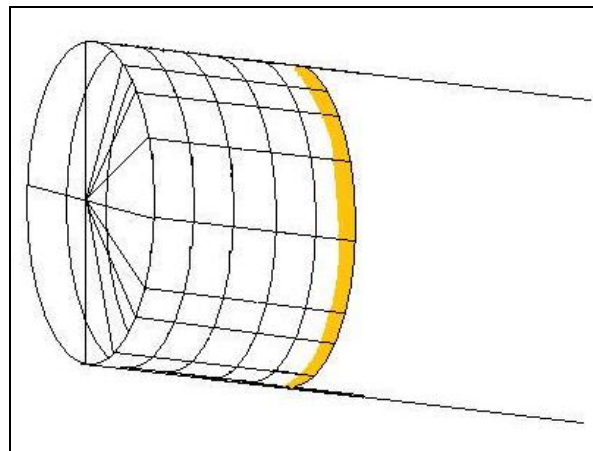

Figure 23 Penetration length, no steering gap case 300kPa

For this case the very low pressures do not produce movement of the grout, because the width is too small, and the advance of the grout starts only for values higher than the earth pressure plus the water pressure. Even then, the scope is short because the soils behave stiffer for reloading; for low values the grout is not able to compress the ground to form an opening. (*Figure 25*)

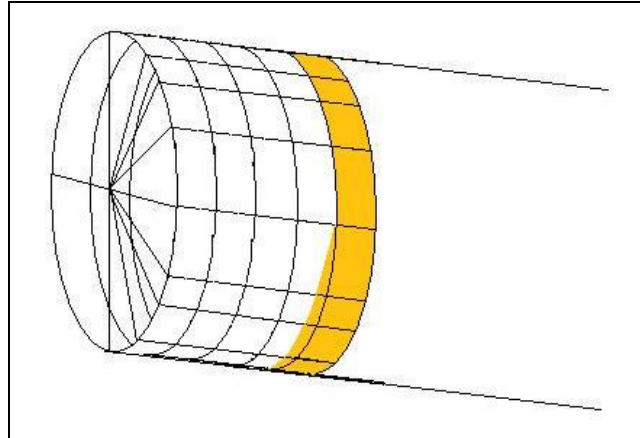

Figure 24 Penetration length, non steering gap case 800kPa

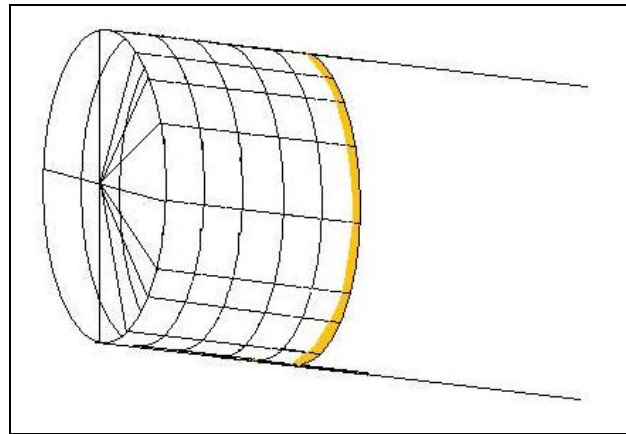

Figure 25 Penetration length, non steering gap case, 250kPa

It is necessary distinguish that two component grouts are not vulnerable to the problem analyzed in this chapter. When the ring is completely filled, the grout has reached the plastic state and will not fluid forward. The traditional mortar requires more precise monitoring of the backfill grouting in this sense. The inert and semi-inert mortars also may behave as the normal grout, but a higher yield stress guarantees the inferior incidence of this phenomenon.

CHAPTER 3

PRECAST SEGMENTAL LINING AND BACKFILL GROUTING INFLUENCE.

The lining of the tunnel has a support function. The precast linings are made before the tunnel excavation, in plants located at the surface, from where are taken to the construction yard and stored there until their montage. They must be organized at surface in the assembling sequence, during transportation by the TBM system to the work site, and allocate through the erector system.

The precast segments permit the concrete to develop appropriate strength, allowing the support to act immediately after the ring is putted in position. It is the principal choice in urban areas because it provides instant control of the settlements, water flow into the tunnel and can sustain the advance of the TBM, carrying out the thrust of the jacking system. It also makes possible, for the TBM pass, hosting the TBM backup system.

The lining is based on rings and segments that are connected between them by bolts or dowels, making them stable. These elements are fundamental on the construction phase, because along with jacks, hold up the segments when the ring is not already complete (*Figure 26*)

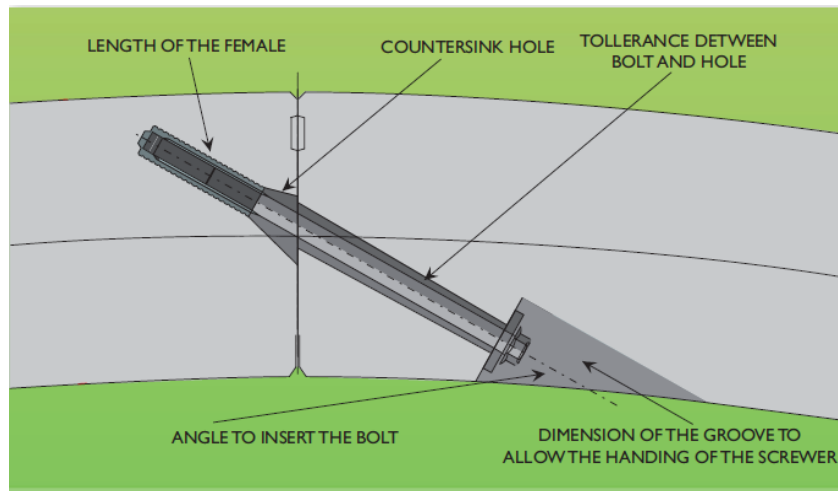

Figure 26 Detail of bolt joint between segments

The rings are equipped with load distribution pads that allow the split of longitudinal forces between them and from the jacks to the lining. This system prevents point loads that can damage the segments, compromising the water proofing system or even the stability.

The support is created as a puzzle, through segments (*Figure 27*). These can have different shapes: hexagonal or honeycombs shape (not commonly used, for the special conditions needed), rectangular (that can be used only on straight sections) and nowadays the most used shape that is called the universal one. This lining has a rhomboidal shape, with some grade of taper, and a trapezoidal segment named “key”, of smaller size. The k-segment is inserted with the smallest part backward and the wider part forward, locking the ring. To giving the wished alignment they are rotated until reaching the straight sense, the vertical or horizontal curves. This method is popular because of its versatility; it can be used for almost any alignment geometry, and with it, deviations produced for the little TBM driven errors can be corrected in situ. Structurally speaking the shape of the segments does not matter, because it does not have considerable influence in the final performance if it is correctly designed.

The ring is positioned by the previously mentioned erector system. That can be based on a vacuum mechanism or on a mechanical one.

The size and geometry of the lining system is decided according to the tunnel diameter and alignment, to the operational features of the tunnel excavation, the machine applied loads and finally the ground loads.

The precast segments can be reinforced with steel bars and/or with fibers (steel or plastic). The total replacement of the steel case is still under study, for obtain a faster method of prefabrication, but not concluding results have been found.

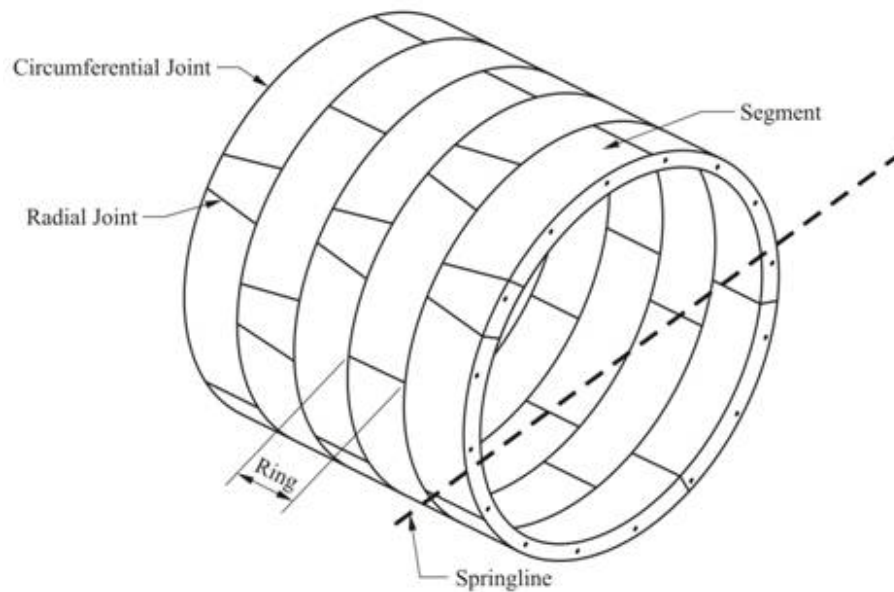

Figure 27 Segmental lining configuration to construct the ring

The structural design must be done for both prefabrication (when the concrete has not yet reached its design value) and exercise period. The single segments must withstand the loads from the extraction of the moulds, the several changes of position and location, and the loads that it will be submitted to during storing and montage. In addition the construction phase regards the jacking forces and the longitudinal injections. Moreover, the long term stability of the segments, rings and joints should be guaranteed. For the support design are usually used the guidelines of the tunnelling associations. The most recognized are:

- Japanese Standard for Shield Tunnelling. Japan Society of Civil Engineers. Published in 1996;
- recommendations for the Design, Sizing and Construction of Precast Concrete Segments at the Rear of a Tunnel Boring Machine. AFTES. Published in 1997;
- guidelines for the Design of Shield Tunnel Lining. ITA. Published in 1999.

According to the ITA guidelines, the safety in the joints between segments must be checked using the limit state or the allowable stress design method, the same used for verify the segment. The verification must regard the three most critical sections (Maximum positive moment, maximum negative moment and maximum axial force). Meanwhile, considerations for the joints between rings are not widely explained, instead it is only expressed that the longitudinal transference of forces depend of the geometry of the joints.

For the calculation of the stresses and strains of lining and joints it is necessary a revaluation of the flexural inertia, because the tunnel lining with its bifurcations has different behaviors as if it were a complete cylinder.

The Japanese Tunnelling Association has proposed a method for calculate the segmented ring inertia, taking into account:

- the rotation of the rings, avoiding two transverse joints being consecutives on the longitudinal direction;
- the different inertias, low for the joints, high for the segments;
- the transport of excess moment to adjacent rings when the joints and segments are not able to sustain it.

The recommend method regard an equivalent cylinder with decrease young modulus, making a differentiation between joint moments and segment moments, by means of the application of the factor ξ . The parameters can vary from 0.3 to 0.5 as a function of the ground stiffness and the number of rings.

The normal forces are not affected by the correction factor, and the new properties of the ring are calculated using the next equations:

$$Ea = (1 - \zeta) * Ec$$

$$Mj = (1 - \zeta) * Mc$$

$$Ms = (1 + \zeta) * Mc$$

where:

Ea = the equivalent young's modulus of the ring

Ec = the young's modulus of the concrete

Mc = the bending moment calculated for the section

Mj = the bending moment of the joint

Ms = the bending moment of the segment

In addition, the Guidelines of the International Tunnelling Association, (2000) contemplate the kind of loads that must be present in the design of the lining as follow:

- loads that must always be considered:
 - ground pressure;
 - water Pressure;
 - dead load;
 - surcharge;
 - subgrade reaction.
- loads that "if necessary" should be considered:
 - loads from inside;
 - loads during construction stage;
 - effects of earthquake.

- and, finally the special loads:
 - effects of adjacent tunnels;
 - effects of settlement;
 - other loads.

Concerning the construction loads, they are, as previously mentioned, the thrust force of shield jacks, the load during transportation of segments, the handling induced forces, the pressure of backfill grouting, the load by operation of erector and others. Not detailed specification is given about the way in which must be considered the installation period and the subsequent phases, before the grout develops the final strength.

Moreover, in these instructions are explained some bi-dimensional calculation methods, and it is recognized that FEM techniques simulate realistically the phenomenon of the excavation, giving the possibility of evaluating on the lining the characteristics of the backfill grouting, its efficiency and the effect on the degree of relaxation of the soil, but again, without specific guidance.

Nowadays, a large number of projects is designed with FEM methods, making possible to insert this variable in the calculation, and with the passing time becomes more important including the backfill grouting influence on the lining design, also catalyzed by the recent interest in the injection effect in the subsidence control.

When the backfill pressure is considered in design period, using computational methods, it is simulated as a distributed force, applied to both lining and ground in one stage and in the next is removed.

For the structural verification of the lining in exercise phase the ITA instructions described this as the most adverse situations that must be tested:

- section with the deepest overburden,
- section with the shallowest overburden;
- section with the lowest ground table;
- section with the highest ground table,
- section with large surcharge;
- section with eccentric loads;
- section with unlevel surface,
- section with adjacent tunnel already present or planned on one of the future.

From these conditions, with the help of numerical software, in actual projects the lining design is made through parametric analysis in which are varied a number of parameters, like the relaxation of the ground and the injection pressures. Also the grouting material is modelled with differentiated properties for both fluid and hardened state. For all the analysis are chosen the most

representative cases, in which, from the grout injection perspective, the soil should compress, avoiding the ovalization of the tunnel but without generating upward movement of the surface. (Guglielmetti et al, 2007).

The moment and the axial forces resulting for every studied case is obtained, and the more unfavourable instance, which lead the tunnel lining to the limit state is choose for the lining design.

Finally, ITA guidelines give an example of design, in which the grouting is considered as a local effect, being used for the verification of the fall of the k-type segment and the segmental ring.

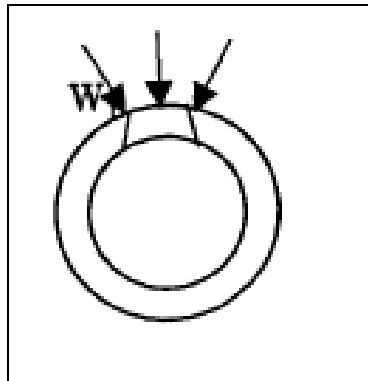

Figure 28 Check of the fall of the K-segment

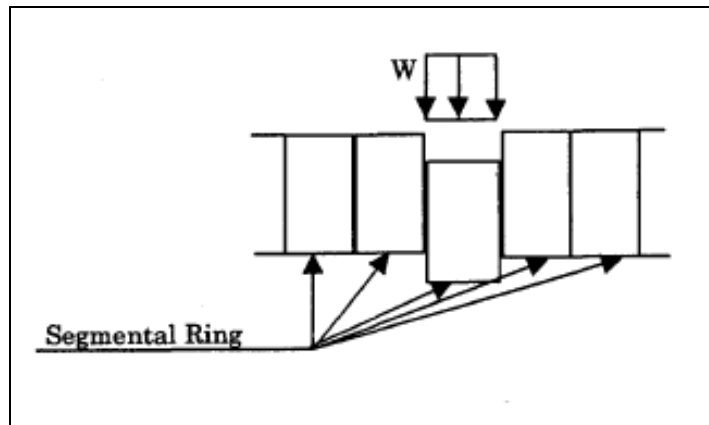

Figure 29 Check of fall of the segmental ring

- Check of fall of K-type segment (*Figure 28*)

$$W_l = \max(p_b; p_l / B)$$

where:

W_l : pressure at the most adverse condition;

p_b : pressure of backfill grouting / Security Factor;

p_l : earth pressure + Water pressure;

B: width of the lining.

$$S_B = (2 * \pi * R_c) * W_l * B * (\theta / 360)$$

where:

R_c : centroid lining radius;

S_B : shear force produce for the p_b or p_l ;

θ : k-segment angle.

$$\tau = \frac{S_B}{n * A} < \tau_{adm}$$

where:

n: number of bolt;

A: longitudinal area of one bolt;

τ_{adm} : shear admissible strength of the n bolts.

- Check of fall of segmental ring. (*Figure 29*)

$$W = (W_l * 2 * R_o * B) + (2 * \pi * R_c * g)$$

where:

R_o : outer radius of the tunnel lining;

$(W_l * 2 * R_o * B)$: force acting one segmental ring by pressure of backfill grouting;

$(2 * \pi * R_c * g)$: weight of one segmental ring.

$$\tau = \frac{W}{2 * n * A} < \tau_{adm}$$

The phase from the assembling to the hardening of the grout is very complex and poorly investigated. The studies of the injection effects are relatively new, with large number of uncertainties, and its consequences are not already contemplated on the internationally recognized recommendations. The unsupported stage, when grout does not ensure the immobility of the rings is essential, because in that moment the most of the deformations occur to the lining.

1. Behaviour of the grout around the tunnel. Affection to the lining

a. Pressures around the tunnel

The behaviour of the grout around the tunnel in the early stages had being monitored by Bezuijen (2003, 2004, 2006) and Talmon (2001, 2006, 2009) in the past years. They found out that the grout pressures upon the lining was higher in the rings near to the TBM, during drilling, when were dominated by the injection pressures and these values decrease in the period of standstill, enhancing again with the advance of the machine, and so on, going down gradually as shown in *Figure 30*. Contrary to the usual thought the gradients were always lower than the hydrostatic pressure of the grout and the final stresses on the lining were close to the pore water pressure.

On bibliography, the ideal way in which the backfill is applied, is seen like a distributed load against the surrounding soil, derived of the uniform pressure injections along the circumference of the tunnel. This load can be taken as four rectangular area loads with the value of the effective pressure injection (p_i') (*Figure 32*). The former is the stress that really arrives to the soil, being: the total pressure injection (p_i) minus the water pressure (p_w). As the injection pressure approx. corresponds to the overburden pressure, the backfill grouting would compensate the stress loose during excavation, and would inhibit the deformations. Regarding the horizontal pressures at the sidewalls, it will be present a pre-stress, because normally in the original state of stresses the horizontal forces are lower than the vertical ones.

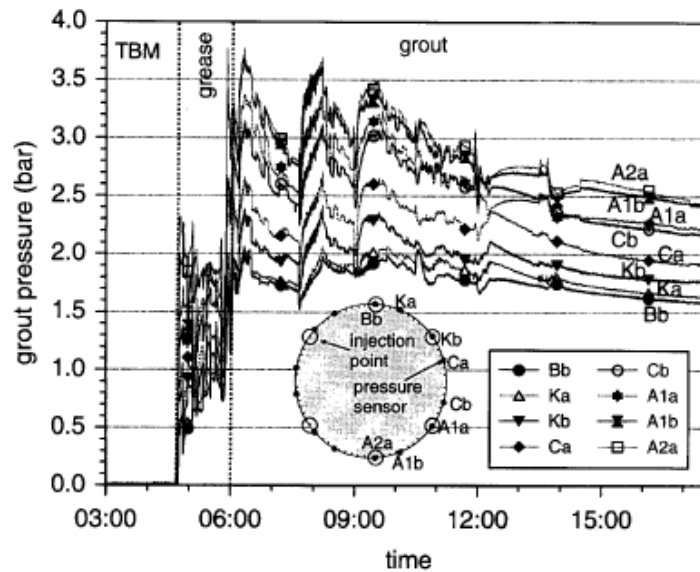

Figure 30 Measured pressures in the Sophia Rail Tunnel.(Bezuijen et al 2004)

On bibliography, the ideal way in which the backfill is applied, is seen like a distributed load against the surrounding soil, derived of the uniform pressure injections along the circumference of the tunnel. This load can be taken as four rectangular area loads with the value of the effective pressure injection (p_i') (Figure 32). The former is the stress that really arrives to the soil, being: the total pressure injection (p_i) minus the water pressure (p_w). As the injection pressure approx. corresponds to the overburden pressure, the backfill grouting would compensate the stress loose during excavation, and would inhibit the deformations. Regarding the horizontal pressures at the sidewalls, it will be present a pre-stress, because normally in the original state of stresses the horizontal forces are lower than the vertical ones.

After the hardening of the grout, in the long term, the grout loads the rings, with a uniform radial load σ_r , which is been estimated by Wittke (2007) as approx the effective injection pressure p_i' .

However, recent studies made in a large overburden tunnels with 2-componet backfill grout have found that not always the long term load upon the lining is the previously suggested. The studies show that the grouting strategy and the final loads on the support depend on the type of soil (Hashimoto et al.2004 and 2009) (Figure 31)

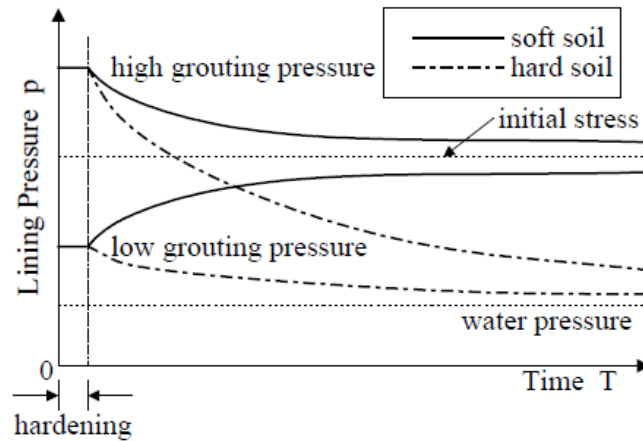

Figure 31 Long term pressures acting upon the lining (Hashimoto et al, 2004)

- in clayey ground (field measurements)

In soft clay ground the pressure on the rings change with the backfill grouting until five to ten rings, depending of the size of the tunnel. Then, the pore water pressure accumulated around the tunnel is dissipated for around 1 or 2 months making the load to decrease. Finally the water pressure keeps stable, and the earth pressure turn to increase slowly, because of the raise of the effective stresses, when the water is dissipated in the farer zone. Finally, it is arrived to a constant value (static pressure +/- cohesion). From many long term data of Japanese labours, it was found that the consolidation of the ground was bound to the earth pressure that would act upon the lining.

Hashimoto et al (2009) described the grade of consolidation based on an empirical relation between the cohesion (C) and the overburden pressure (Pv0) as follow:

$$2C \leq 0,3Pv_0 \text{ Unconsolidated}$$

$$2C = 0,3 \div 0,4 \text{ Natural Clay}$$

$$2C \geq 0,5Pv_0 \text{ Over - Consolidated}$$

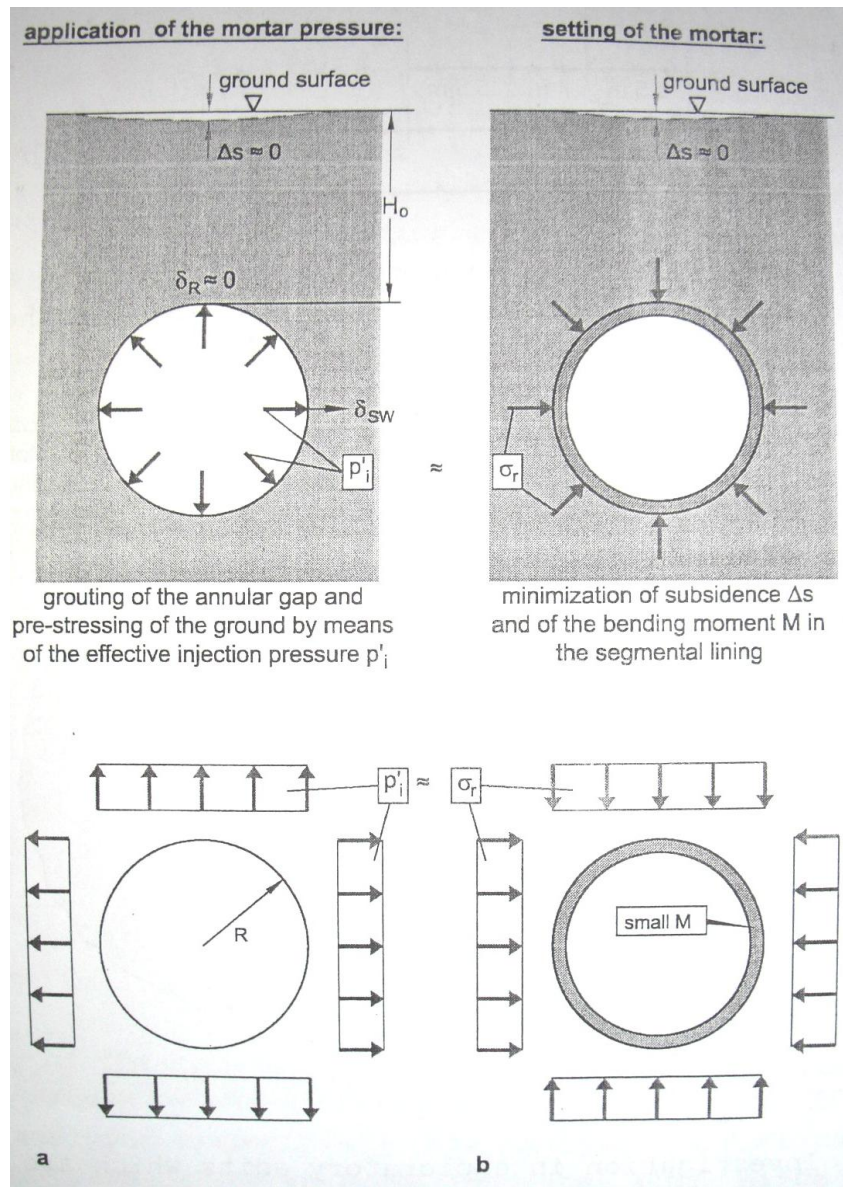

Figure 32 Pressures acting around the tunnel regarding the backfill grouting. (Witke, 2007)

When the ground is unconsolidated, the collapse of the ground annulus after the TBM passing is likely, loading the lining with almost all the overburden pressure and making the backfill grout difficult (Figure 33). Therefore, the injection procedure does not affect mostly in the final load of the lining and the value of the P_v/P_v0 tends to 1, where P_v is the effective earth pressure upon the support and the P_v0 is the overburden pressure.

For the hard clay grounds it was verified that the earth pressure depends largely of the injection pressure and ratio. The definitive earth pressure is build up at the first 10 rings, provided for the backfill process. In that sense, the final earth pressure can be bigger than the Terzaghi's load. The latter is because of the annular gap in hard soil remains stable and the grout can go into evenly, bedding

in effective way the ring. It is also noted that the settling of the earth pressure needs just days, much quicker than the soft clay.

When the ground has a stiff consistency, the backfill can be done before of the fall down of the soil on the segmental lining. Then the relation between the soil stiffness and the grout material stiffness becomes important. When those have similar rigidity the interaction became active, making the earth pressure varying largely according the backfill and the construction conditions. In the case of a very rigid ground, the shrinkage of the grout is superior respect to the deformation of the soil, namely the backfill grout does not affect the loading, and the coefficient P_v/P_{v0} is almost zero.

The horizontal forces have been studied through the parameter of $P'h/P'v$ (relation between the effective horizontal pressure and effective vertical pressure), for long term data. There have been found values around 0,45-0,5 for unconsolidated grounds. Instead for over-consolidated clays, the parameter value may vary considerably, therefore it can be concluded that also for this kind of ground, the load radial distribution depends of the injection strategy and the construction conditions.

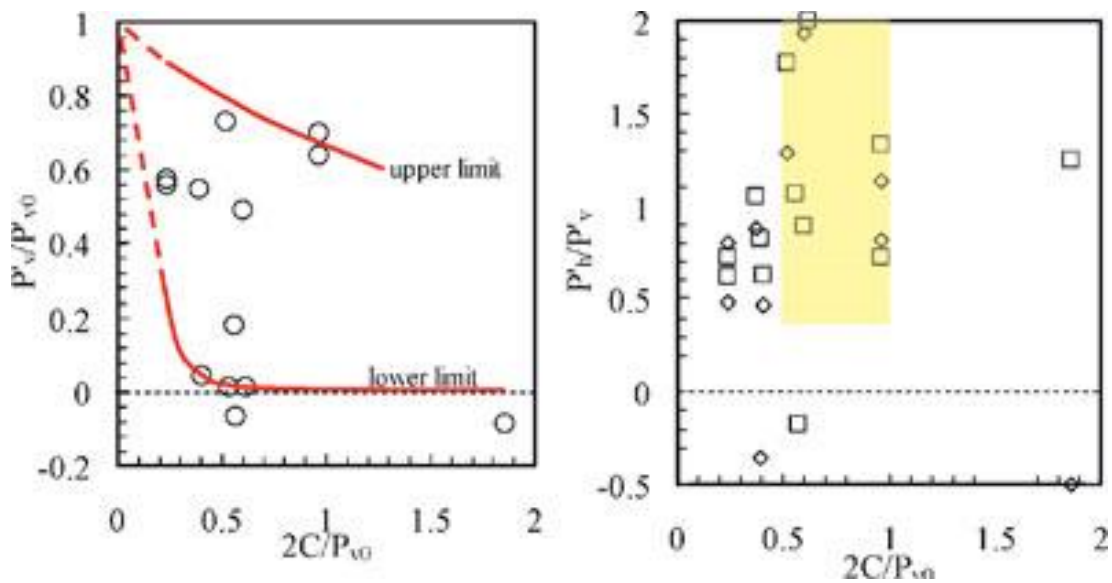

Figure 33 Relation between overburden pressure and actual acting pressure (clayey soils) (Hashimoto et al, 2009)

- in sandy ground (field measurements)

It was discovered that the initial loading on the lining was higher as higher was the injection pressure. In the long term, the pressures do not change significantly, remaining the level of the injection influence, and the earth pressure became stable much faster than in clayey grounds.

The same analysis for long term data was made, but the parameter of strength used was the SPT-N (Standard penetration test). When the material has good conditions the backfill can be done before the ground detachment into the annular gap, and the backfill technique has better influence. If too high pressure is used, the soil can be loaded permanently, or if is made a good grouting process the stresses can be reduced.

Similarly to the clays, when the material is very weak, the injections cannot be made appropriately, and the load acting on the lining is close to the Terzaghi's calculation. Also when the material is a very dense sand or gravel (values SPT>100), the shrinkage affects the grout more than the deformation to the surrounding soil and the earth pressure acting on the lining is very low.

It can be seen in *Figure 34* that the most challenging grounds for the effective earth pressure (P_v) calculation are those with and intermediate stiffness, because are more dependents of the backfill and construction circumstances.

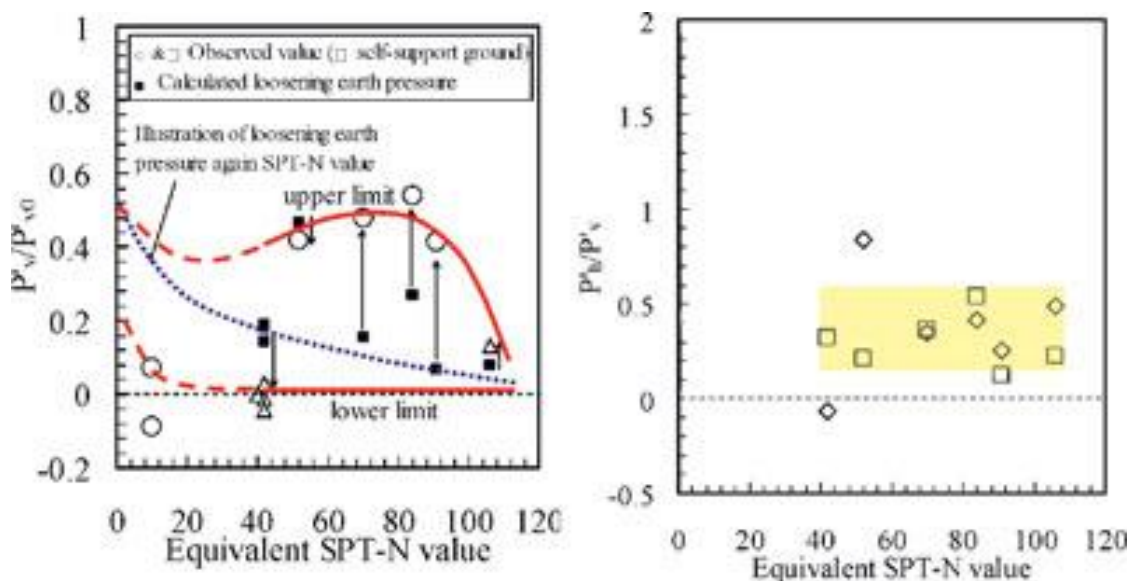

Figure 34 Relation between overburden pressure and actual acting pressure (sandy soils) (Hashimoto et al, 2009)

b. Bleeding and Hardening. Consequences

After the application of the grout in the tail void, the grout can pass through volume changes that will modify the lining loads, and lead to surface settlements. The volume loss of the grout can take place based on two processes: the consolidation or the hardening of the grout. The consolidation consists in the lost of water, in permeable soils, with subsequently increase of the yield strength of the grout. When conventional grout is apply to granular soils, usually loose 5 to 10% of the volume, due to bleeding. The hardening occurs at impermeable soils as rock or clay, when there is no chance of expels the water.

The presence of one or the other is guided by the relation of the permeability between soil and grout, and the internal structure of the mortar, in which prevail the hardening time or the bleeding time.

Laboratory tests (Bezuijen 2007) have proved this process for different types of grouts, obtaining lower losses from the utilization of 2-componente grout (3%), respect to inert mix, or cement mortar. Based on the low filtration and deformation rate, the 2-components grout injected at the tail void can be treated as a closed annular ball, of an uncompressible fluid. Therefore, when the soil treats to enter on the annular gap, pushing to the grout, this will response uniformly upon the lining avoiding punctual deformations. Consequently for an effective performance the backfill must guarantee the following aspects (Pelizza et al.2009):

- the annular gap must be completely full, and the material must remain uncompressible;
- the permeation to the soil and the passage to the steering gap must be restrained;
- the segments installed cannot have deformations;
- the backfill material cannot be leach;
- the material must harden progressively and too quickly for permitting the creation of the uncompressible ball.

On the other hand, when using inert mortar or conventional grout, a considerable volume loss can lead to a substantial pressure reduction in sandy soils, originated by the densification of the ground after the injections around the tunnel. Since the shear modulus for unloading is higher, the original stress distribution will not be present anymore in the long term, aspect that should be taken in consideration for the lining design. In field measurements is noted that the pressures around the tunnel decay during the standstill and after several rings the machine is passed. Normally the hardening it is not reach in that time, but it seems likely the decrease is caused by the bleeding of the mortar.

Assuming an elastic deformation and a constant diminution of pressure in the surrounding soil, it can be related the change in grout pressure with the reduction of the grout layer due to consolidation as follow: (Verruijt, 1993)

$$\Delta\sigma = 2 \frac{\Delta r}{r} G$$

where:

$\Delta\sigma$: change in pressure;

Δr : change in radius. In case of consolidation of the grout, it will be equal to the thickness of the water layer that is expelled from the grout;

r : radius of the tunnel and the grout;

G : shear modulus of the soil around the tunnel.

This stress reduction is related to the increase of the consolidated layer respect to time.

The shrinkage of the grout depends in a determinant way of the groundwater pressure and the injection pressure (Yue-wang Han et al, 2007). The pore pressure main effect is to reduce the permeation rate of the soil, and to cause the decline of the deformation rate. Increasing the injection pressures the shrinkage will be higher and deformation rate will accelerate, because of the drainage of water from grout to soil enhance. It was report that the groundwater had an even bigger influence than the grout pressure.

The consolidation process was also studied in situ in an excavation with slurry shield (Talmon et al 2008). It was added the affectation that can carry the bentonite used at the face on the consolidation process. The mud can raise the hydraulic resistance getting into the soil, through a filter cake formation around the grout or blocking mechanically the pores.

c. Gradients around the tunnel

In some field measurements on granular soils using different types of grouts was studied the pressure distribution around the lining. It was found that pressures increase more or less linearly with the depth, and their allocation is almost symmetrical respect to the vertical axis (Bezuijen et al, 2004)

Several field measurements have showed that the vertical pressure gradient on a ring change with time. It was demonstrated that the pressures are not only linked with the hydrostatic grout pressure as shown in *Figure 35*; otherwise the gradient would be constant in time. The found pattern was a reduction of the gradient in time and as the distance from the TBM was larger.

The pressure gradient around the lining in the first rings is governed by the buoyancy forces and the injection pressures. The buoyancy is caused for the difference of density between the grout and the tunnel (lining + empty volume in the centre). It produces an uplift of the tunnel lining, avoided by the friction between the walls and the grout, which exerts a downward force (*Figure 36*).

When the TBM advances injects simultaneously the grout into the tail void. The successive rings are surrounded of fresh mortar that cannot build yield stress while the machine moves. Therefore high pressure gradients are present, governing the hydrostatic pressure distribution. During the installation of the next ring, the grout can develop shear resistance.

Far from the TBM, past several rings, the grout is no longer influenced for the injection pressure, and it is consolidated, consequently, the buoyancy forces are counteracted and the pressure gradient decrease.

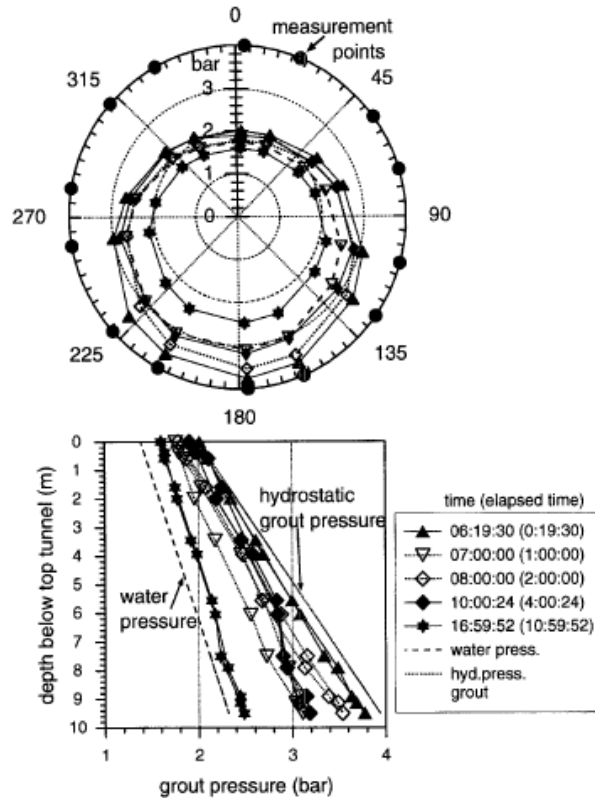

Figure 35 Pressure gradient measured in the Sophia Rail Tunnel. (Bezuijen et al 2004)

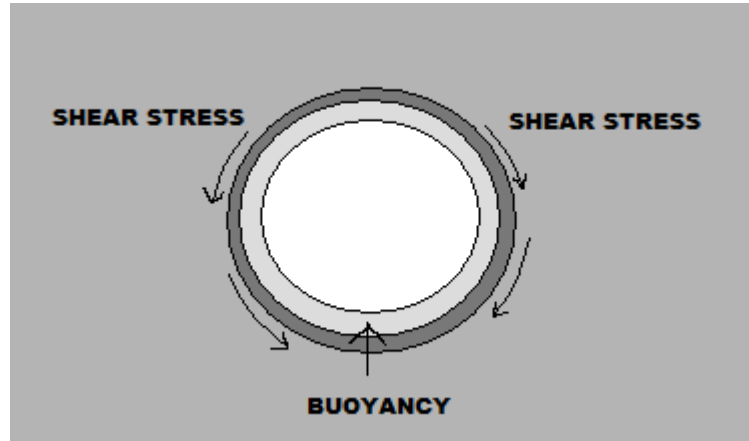

Figure 36 Buoyancy Mechanism Scheme

Bezuijen et al (2004) have made a model for the estimation of the maximum buoyancy force that can be compensated by the intrinsic characteristics of the grout mortar. It is based on the calculus of the shear resistance of the grout, and parallel the evaluation of the buoyancy. Thus, for avoiding the movement of the tunnel the first term has to be greater than the second one.

$$F = \tau_y * \frac{D^2}{s}$$

Where F is the maximum force per meter tunnel lining that can be compensated by the yield stress in the grout, τ_y the shear strength of the grout, D the diameter of the tunnel and s the width of the tail void. The buoyancy force K per metre lining exerted by the tunnel lining can be written as:

$$K = \frac{\pi}{4} D^2 (\rho_g - \rho_t) g$$

where:

ρ_g : density of the grout;

ρ_t : average density of the tunnel (lining and air);

g : acceleration of the gravity;

Then, for reaching the equilibrium in a cross-section:

$$\tau_y \geq \frac{\pi}{4} s (\rho_g - \rho_t) g$$

Since the wall shear stresses exerted by the grout generate a force against the upward displacement, can be concluded that there is a component of the vertical gradient pressure that depends of the yield strength.

Talmon et al. (2001) developed a model to calculate the pressure distribution around the tail void due to injection, which is based on:

$$\frac{dP}{dz} = \rho_g g - 2 \frac{\tau_y}{s}$$

The first part of the equation concerns the hydrostatic load, while the second term adds the influence of the buoyancy. Close to the tail void, the yield strength is low, and the term tends to the hydrostatic load. Further from the TBM the gradient is mainly controlled by the buoyancy, and has a value near to the pore pressure.

In the case of 2-components grout, the hardening is fast. There are present high gradients of pressure when the rings leave the TBM, because of the super liquid state of the mix, with very low shear strength, but, just finishing the drilling, the gradient settles in the equilibrium value. The low density and the fast development of strength reduce the influence of the buoyancy forces, and the affectation of the injection of the new segment to ones that are been previously built.

The grout mortar can be designed with a determined density and yield strength with the aim of counterbalances the buoyancy forces. It is also known that besides the buoyancy there are other requirements that must be accomplished; i.e. the injection pressure. Therefore, the grout must flow easily through the pipes. Because of the ambiguous properties that should be achieved, sometimes the yield strength of the grout cannot counteract the whole uplift force, and some stresses are passed to the lining elements still in the TBM and to the rings in which backfill is already hardened. This condition characterizes the longitudinal load behavior.

For the study of this phenomenon the lining can be modeled like a beam, supported on the terminal points, the TBM machine in one side and the already harden grout in the other side. If the grout has a too slow development of the yield strength, the beam could deform, damaging the longitudinal junctions, and transmitting high bending moments to the lining and to the TBM, in which can be affected the tail brushes, implying important costs, time, and possible loss of pressure on excavation chamber. The only way of controlling these effects, is maintaining as short as possible the unsupported length on the lining tube. Bezuijen et al.; have report 3 options to achieve it:

- high initial shear stress, for counteract the buoyancy forces, even if the grout is not already hardened;
- fast consolidation of the grout, enhancing the yield strength in a short period. This is only possible if the grout and ground characteristics allow it. For clays with a low permeability it is not an option;
- quickly harden of the grout

CHAPTER 4

QUALITY CONTROL METHODS

The backfill grouting is relatively a new technique, and today it is basically design using an empirical approach. The properties that must achieve the grout are not determined, principally because the behaviour of the tunnel in the injection phase is not well known. Consequently, the testing methods for the compounds are not standardized and it is becoming necessary to set up a general guidance to establish the most appropriate testing techniques for the tail void grouts.

Frequently the effectuated assessment to the backfill mortars is based on the tests required for general concrete, highly normalized. These regulations are imposed by important standards associations such as the ASTM, the British Standards Institution or the AASHTO.

For the two component grouts the quality control is generally conducted for every part individually, where the component A usually follows the requirements of the other kind of mortars and the properties of component B should be as described by the manufacturer or supplier of the product. The quality of the Component B should be determined by regular tests or by a Quality Assurance Certificate provided by the producer. The combination of the two

components is not normalized, and only should meet the prerequisites indicated by the contractor or by the project specification.

The tests that are commonly carried out for the quality establishment are:

1. Grading Curves of the aggregates

It is a diagram that shows the grain size distribution of the material, obtained making pass the compound through diverse sieves, with decreasing dimension.

For some projects using semi-inert mortar (Shirlaw et al, 2004), it was demonstrated that the well gradation of the mixture can confer a high-quality rheology to the grout and it is key factor to counteract the flotation of the rings when the harden zone it is not arrived yet. It is recommended regulate the gradation of the aggregates separated and combined. Also, this test is required for the aggregates of cement based mortars, and for the pea gravel.

Nevertheless, there are not standards that restrict the range of sizes or suggested proportions. Often the grout design is based on experience, trial and error, and common sense.

2. Compression Strength

The resistance require for tail void grouts is not high. The function of the grouting is to connect and transmit the load from soil to lining, the one that really has the structural function. The strength needed is such that could withstand the soil stresses without the appearance of fissures, because they might compromise the water proofing and increase the settlements.

The whole performance of the backfill, including the strength, can be affected for the presence of voids in the annular gap, as consequence of a mediocre grouting system. Recently this situation can be controlled employing radars and geophysical methods. The advantage of these procedures is that they are not destructive and can be executed as many times as the operator wants, permitting a wide interval of monitoring areas.

The traditional technique used to verify the quality of the backfill is usually the random core extraction. This technique allows the direct visualisation of the defects and subsequent compression tests to the cores.

Moreover, during or before the tunnel construction grout cylinders or cubes can be prepared grout with the same dosage of the used in the work. The compression strength test can be executed on them, using this approach approximate values can be obtained. The compression tests are internationally regulated, because are typical practice in the concrete production and the rock categorisation.

Sometimes, for two component backfill grout, the test on cube samples can be inaccurate. The resistance of this kind of mortar depends on the links created between component A and B during the injection. When the process is

done by an operator the mixing can be inefficient and the cubes could present great disturbance. The reliability of the tests has elevated dependence of the human factor, therefore must be managed with high attention.

In addition, recent studies have determined the importance of the grout during the early stages after the passing of the TBM. The concrete and inert mixes do not develop considerable strength in the first hours, but the two component backfill does. Consequently for two component grouts also are required certain resistances after a few hours of combined the components. The determination of the gel compression strength is being tested using no-standard methods, as modified Vicat Apparatus. (Pellegrini et al, 2009)

3. Bleeding and volume loss

The bleeding is a way to measure the stability of the mortar, to identify whether there is segregation or not. Also, this is an important parameter because when backfill lose volume permits the entrance of the soil into the tail void and contributes with higher settlements.

The bleeding test can be done following the specifications of the normative ASTM C940 "Standard Test Method for Expansion and Bleeding of Freshly Mixed Grouts for Preplaced-Aggregate Concrete in the Laboratory". It is place a certain quantity of grout (500 to 1000ml) in a graded cylinder and must be verified the volume of water that separates from the mortar through time (*Figure 37*). The first measure must be done at 3 hours after, and it can be repeated at 12 and 24 hours.

The value of expelled liquid cannot exceed the 3% of the initial volume after 3 hours. Although, Linger et al (2008) established that the optimal value should not be higher than 1% in 2 hours.

The two processes involved in the volume loss are the hardening and the bleeding of the mortar; one or another will be present depending on the proportion between the soil and grout permeability. If the hardening time is lower than the consolidation one, the grout will cure faster than it expels the water, and consequently the bleeding will be small.

For analyzing this complicated phenomenon, in which many factors are involved: hardening time, permeability of the soil, permeability of the grout, pressure into the annular gap, etc, Bezuijzen et al (2007) have developed two devices, one for testing the consolidation in permeable soils, where logically the bleeding predominates to the hardening, and another for studying the behaviour of the grout between lining and cohesive soil, both with very low permeability.

The scale is very important, since the bleeding and hardening have non linear dependency to the width of the grout layer. Therefore, the set up tests are constituted by a cylinder of 30cm of diameter and a grout layer of 20cm, the same order of magnitude for real cases.



Figure 37 Used instrumentation for the bleeding test (Pellegrini et al, 2009)

The configuration of the apparatus is sketch in *Figure 38* and *Figure 39*. Both have the same principle but the drainage is different and so the possibility of measure the pore pressure. By means of the plate, the pressure is applied (the amount is not normalized, but they use a range of 1 to 3 bars), and the expelled water is measured.

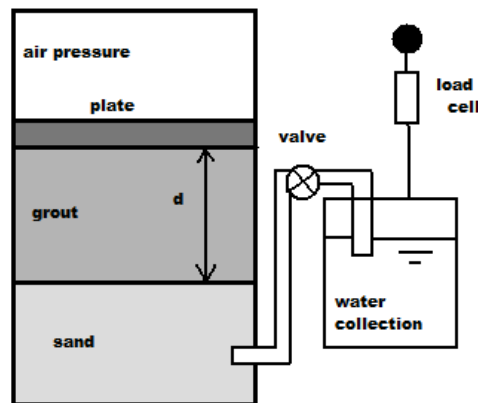

Figure 38 Measurement principle for permeable soils. (Bezuijen et al, 2007)

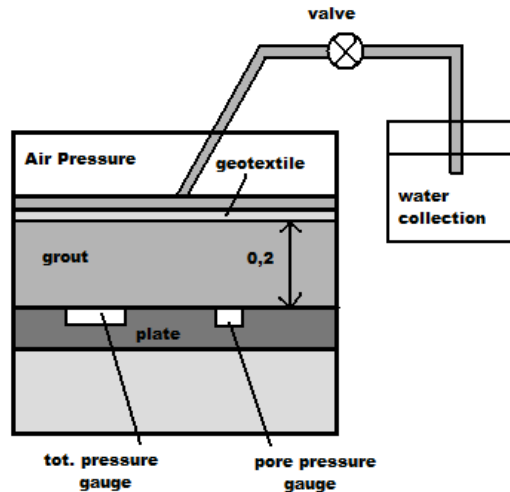

Figure 39 Modified test set up for permeable soils. (Bezuijen et al, 2007)

When it is supposed an impermeable soil, the test set up is like *Figure 40*. For this experiment it is applied constant pressure at the air supply, in the order of 1 bar, and the volume loss is quantify measuring the changes of the water column on the top of the container. It is known that the changes in the water levels lead to pressure variations in the grout, but related to the induced pressure this value is very low, and can be neglected.

In addition, it is measure the shear strength while the process is done, using a vane test every several minutes.

For the first procedure were tested: a cement based mortar, an inert mix and a two component grout. It was found that:

- the cement mortar had 8% of water loss at 300kPa;
- the inert mix arrived to 4.5% of expulsion at 100kPa;
- the two component grouts reached 3.5% of volume loss at 100kPa.

The two component grout continues expelling water until 5 hours after the initiation, while the inert mixture finished after 0.5 hours. It was expected that the cement mix could have lower losses value applying lower pressures.

Regarding the shear strength, the values were increasing since few minutes of started the test, as consequence of the consolidation. When the tests were previously executed at atmospheric pressure the hardening initiates 5.5 hours after start of the trial. (Bezuijen et al, 2002).

For the impermeable conditions, it was only analyzed the two component grout. In this situation there is no place for the consolidation and the volume loss is completely responsible of the hardening. The test arrived to a 2,8% of water expelled after 125 hours, in which the volume stabilised.

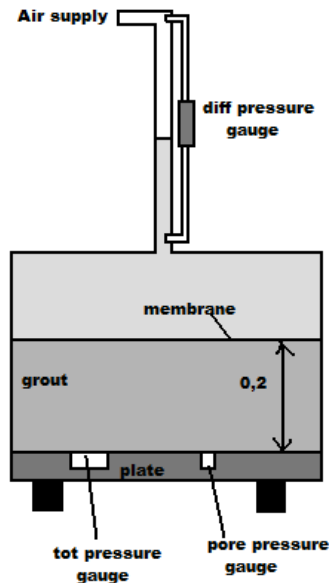

Figure 40 Test set up scheme for impermeable soils. Bezuijen et al 2007

Similarly the water loss under pressure was tested for semi inert mortars by Linger et al (2008), using an in house test, conformed by a small perforated and drained cube. They considered that the bleeding under pressure of 1bar for half an hour must produce at tops to 5% of bleeding.

Even when these systems seems promising, there is not data about the values that guarantee the most effective performance in the tunnel construction yet, neither the restrictions that must have these parameters for avoiding significant problems in the work site.

4. Workability:

The backfill mortars need to be very fluid before its application, to access uniformly to the annular grout filling it completely and for flowing correctly in the pipes. If the grout has too high viscosity, inefficient functioning can occur.

The workability can be tested for two different moments: the injection instant or the after application moment. Usually the consistency of the concrete mortars is tested with the Slump Test, and its results are used to establish a pattern of behaviour between different mixes, prepared in different moments. A change in slump height would demonstrate an undesired change in the ratio of the concrete ingredients that could be adjusted. Instead, when the mortar is still for being pumped, it is too fluid, and its viscosity and workability can be analyzed using the Marsh Cone Test.

The traditional slump test is control by the normative ASTM C143 "Standard Test Method for Slump of Hydraulic-Cement Concrete". It is performed using an apposite apparatus called Abrams cone, conformed by a plate and an empty cone above it. (*Figure 41*) The container must be filled with the mixture, first one-third, be rod 25 times with a steel bar, and repeat the procedure filling it two-thirds and finally completely. Afterwards the cone must be lifted, the concrete

will flow, and when it will be stable the difference between the initial height and the current height will be the slump value. (*Figure 42*)

For semi-inert mortars, it is suggested by Linger et al, (2008) initial slump values of 100-110mm, and after 24 hours, from 70-90mm, performed with a small mortar cone. This value could be used also for cement based mortars that must have similar properties. (*Figure 43*)



Figure 41 Abrams Cone

However, in two components mix, for the workability assessment of the component A, the property of interest is the viscosity, to characterize the flow capacity during batching and pumping.

The Marsh Cone Test is adequate in the determination of the fluidity of the compound A, and is regulated by the normative ASTM C185. The procedure is made using standardise funnel (*Figure 44*). The mixture is added from the top while the exit is temporarily impeded, until the cone is full. Then, the aperture is unblocked and the time that takes to 1000ml leaving the funnel is measured.

The optimal value is often recommended for the supplier with respect to the design, where are already considered the project needs. The flow time of the mixes in the worksite must be within 15 seconds of the suggested one.

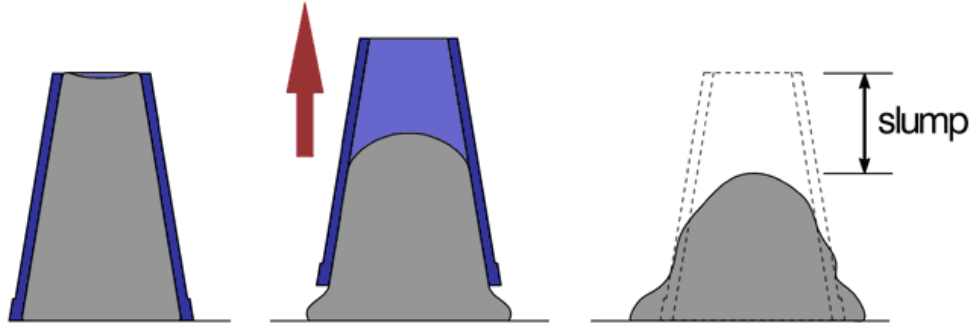

Figure 42 Slump test procedure



Figure 43 Inert Mortar Slump Test. (Linger et al, 2008)



Figure 44 Standard Marsh Funnel.

Additionally, it is also important to have some knowledge about the workability of the two component grout when it is in plastic state. The gel time test

is widely performed, but no strict lineaments are established. The procedure is to mix the constituents of the grout and measuring the time in which becomes gel. There are not specifications about when considering the change of state, leading to uncertainties.

5. Durability

Testing the durability of the grout is a process that takes months and years. Generally the durability test takes place curing samples of the grout under the same conditions that will find in real situations (temperature, humidity, ph, etc.) and after some time makes a visible inspection followed for complementary tests, convenient to determinate the damage suffered by the grout.

The durability verification is made based on the observation of the degradation and deformability. The grout must remain intact without considerable deformations; consequently also the volume loss assessment can be a way to estimate the durability. Finally, another indicator that will lead to stability of the mortar is the impermeability, must be kept during the years and also must be subject of verification in the durability tests.

6. Shear Strength

The grout behaves following the Bingham model, so it is becoming very important the determination of the yield stress and the development of the shear resistance, in order to understand the mechanisms present in the first stages after the TBM advance. The determination of this parameter and for cohesion as well, is done using the vane test. This method is been used for testing gels, slurries pastes and other soft solids. The apparatus is normally a four-bladed paddle that is inserted in a container filled with the grout. The instrument is rotated generating the deformation of the sample and the yield point or shear strength is calculated based on the torque. (Figure 45)

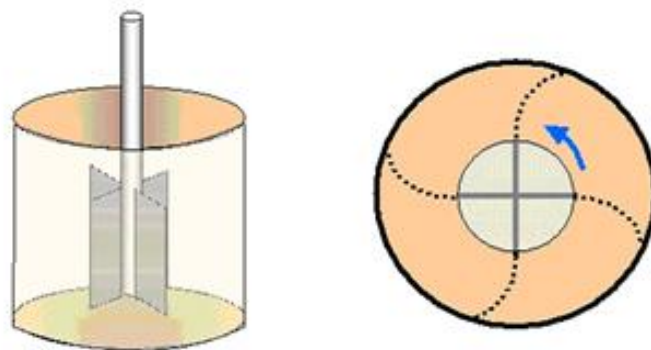

Figure 45 Vane Test Scheme (www.rheology.com)

The backfill grouting is today a very important topic, because there is the need to optimise the process for reducing the settlements. Each investigation has its own needs, and based on that, new tests will be produced. Those which already exist will be modified, and perhaps in the future it will be a normative with

detailed specifications for every experiment. Supplementary tests that are also been practiced in diverse investigations are: Relaxation Test, Wash-Out test, Internal Friction, etc. (Shirlaw et al, 2004)

Moreover, with the aim of simulate the behaviour of the grout using numerical methods, it is important the determination of the elastic modulus and Poisson ratio of the mixtures when are fluid and when they harden. For concrete this topic has been studied before, but for other types of grout there is not available information. Then, the determination of a method to characterize the mechanical properties of the mortars at early stages is demanded.

Politecnico di Torino Tests

During the execution of the Line C of the Roma subway, the staff of the Centro per le Gallerie e lo Spazio Sotterraneo (TUSC), of the Politecnico di Torino, tested the properties of the two component grout used. Considering the little information that is available about the two component grout, this research has brought valuable data about the grout behaviour.

The backfill grouting is design by the manufacturer company, regarding the essential features for the tunnel excavation. Some properties are established as the optimal ones for the project; the mixtures and components in practice have to fulfil them. As it was stated before, nowadays, there is not explicit regulation in order to guarantee the requirements imposed in the contract, so the laboratory tests were focused into verify them.

The suggested features for the present mix were:

The component A must:

- maintain the workability at least for 72 hours;
- flow time for the Marsh cone test from 30 to 45 seconds;
- bleeding lower than 3% after 3 hours.

The grout mixture must:

- gel formation time, from 10 to 18 seconds;
- compression strength after 7 days from 1.8 to 2.5MPa;
- compression strength after 28 days from 3.5 to 6.0MPa;
- no dilution by the ground water.

The first batch of proves examined the characteristics of the component A separately, checking the viscosity and the bleeding. These parameters are related to the workability, the evasion of clogging problems into the pipes and the stability of the mortar in time.

The samples were taken from the batching plant in the worksite by qualified personnel.

- Bleeding test:

The bleeding experiment was effectuated following the alignments of the ASTM C940 normative mentioned earlier, obtained the results listed in *Table 16*. The volume loss was within the accepted values.

Sample	Volume [ml]	Time from the mixture preparation	Bleeding at 3h [%]
A	500	0 h	3 %
B	500	12 h	2 %
C	500	24 h	2%

Table 16 Bleeding Test Results.

These values are consistent with the established for the supplier company, but are not within the interval instituted by Linger et al, 2009. No proves of bleeding under pressure were done.

- Marsh cone test with nozzle of 4.7mm

The test was performed following the normative ASTM C185, which is widely known. Usually, the producer companies of the two component grouts establish the right amount for this test in the contract, according to the project requirements. The results are shown in *Table 17*

Sample	Time from the mixture preparation	Sample Volume [ml]	Spent Time[s]
A	0 h	1000	33
B	12 h	1000	32
C	24 h	1000	32

Table 17 Marsh Cone Test results.

The flow time recommended by the manufacturer went from 30-45 seconds. The outcome is in line with expectation, because it is within the suggested range.

Afterwards, the tests were extended to the mixed components.

Because of the impossibility of obtain samples directly from the TBM machine, the mixing process was made manually, trying to avoid high disturbances.

It was introduced the component A in a container which was constantly in movement, with a posterior adding of the accelerator material, formed basically of sodium silicate. The grout was keep shaking attempting to simulate the injection of the mortar until it was perceivable certain grade of harden. This was provoked

by component B (accelerator additive) which renders the grout a gel and produces the immediate development of resistance.

The proportion of raw materials of the finished two component grout (Component A plus Component B) is shown in *Table 18*.

Component	Quantity [Kg/m ³]	Specific Weight [Kg/dm ³]	Quantity [l/m ³]
Water	796	1,0	796
Sodium Bentonite	35	2,65	13,2
Cement "Moccia" IV/B-P 32.5 R	350	2,8	125
Retardant Additive	6,4	1,28	5
Accelerant Additive	84,8	1,39	61
TOTAL	1272,2		1000

Table 18 Dosage of the tested two component mix.

- Gel formation time:

The efficiency of the mortar depends on the transformation of the grout from a super fluid substance to a gel, in plastic state. The time that takes the grout to convert itself was measured introducing the two components in a container according to the established proportion (0.5l of component A and 48g of component B). The instant in which was not anymore possible to transfer the grout from the container was assumed as the gel formation moment, since the grout had lost the workability (*Figure 46*). The time from the mixing until the gel creation, was measured and reported in the *Table 19*. They were tested three situations respect to the preparation of the component A of the mortar: just after the combination of the ingredients, passed 12 hours, and passed 2 hours, evaluating the influence of the seasoned component A.

Sample	Time from the mixture preparation	Sample Volume [ml]	Gel-time [s]
A	0 h	500	12
B	12 h	500	12
C	24 h	500	13,5

Table 19 Gel time Test Results.



Figure 46 Sample before and after the gel time test

- **Compression Strength Test**

After the preparation of the grout, it was preserved under water taken from the worksite, in order to simulate the environmental conditions that normally the real grout is subjected to. When the compound was completely hardened, approx past a week, they were perforated samples, from which were extracted cylinders of 54mm of height and diameter.

The samples were conserved in different conditions. Some were cured under water or soil (40% humidity) from the tunnel excavation site, to evaluate the local abrasiveness effect. While, the second round of cylinders was preserved in a special place controlling temperature (20°C) and humidity (95%).

The first portion of cylinders were crushed in different batches: at 7 days, 28 days, 60 days, 70 days and the second after 90 days, 120 days and 180 days, to observe the behaviour of the mix at short-medium-long term (*Figure 47* and *Figure 48*). Besides, the compression resistance study, the additional transcendence of the performed test was to study how the two components grout maintained its characteristics through time. This research also permitted to

observe the durability of the mortar, which is not widely known. Results are listed in *Table 20* and *Table 21*.



Figure 47 Compression Strength Test Instrumentation.

The Italian normative UNI 10834 “Calcestruzzo Proiettato” consider the perforation of cylinders a disturbance factor, as consequence of the vibration and mechanical influence of the drilling instrument. The latter, according to the regulation, might decrease the resistance in 20% approx. As it is explained earlier, there is not legislation or others investigations as extensive as this about two component grout, so it was assumed that the resistance in place is 1.2 times the one obtained, but seems likely to be even higher.



Figure 48 Compression Test. From left to right: Cylinder 8/ Cylinder 9/ Cylinder 12

Cylinder	Curing Time	Curing Condition	Compression Strength σ_c [MPa]	Compression Strength acc. to UNI 10834 $\sigma_c * 1,2$ [MPa]
1	7 days	Water	0,8	0,96
2	7 days	Water	0,9	1,08
3	7 days	Water	1	1,2
4	7 days	Water	1,1	1,32
5	7 days	Water	0,7	0,84
			Aver. Strength (7days)	1,08
6	28 days	Soil w=40%	2,1	2,52
7	28 days	Water	2,6	3,12
8	28 days	Water	1,3	1,56
			Aver. Strength (28days)	2,4
9	60 days	Water	1	1,2
10	60 days	Water	2,8	3,36
11	60 days	Water	2,9	3,48
12	60 days	Soil w=40%	2,1	2,52
			Aver. Strength (60days)	2,7
13	75 days	Soil w=40%	2,8	3,36

Table 20 Results of the compression strength test for the first round of samples.

Cylinder	∅ Cylinder [mm]	Cylinder Section [mm ²]	Curing Time	Compression Strength σ_c [MPa]	Compression Strength acc. to UNI 10834, $\sigma_c *1,2$ [MPa]
14	54	2290	90 days	3,36	4,03
15	54	2290	90 days	3,32	3,98
16	54	2290	90 days	3,78	4,54
				Aver. Strength (90days)	4,18
17	54	2290	120 days	4,54	5,45
18	54	2290	120 days	4,43	5,32
19	54	2290	120 days	3,73	4,48
				Aver. Strength (120days)	5,08
20	54	2290	180 days	4,02	4,82
21	54	2290	180 days	4,58	5,5
22	54	2290	180 days	4,47	5,36
				Aver. Strength (180days)	5,23

Table 21 Results of the compression strength test for the second round of samples.

The test results have proved that the two component grout behave efficiently, conserving its properties, increasing the resistance in time, regardless the preservation conditions. Additionally, the resistance developed was into the range of strength that the manufacturer company established in the contract for the Rome line C subway.

- Durability Test

Before the realization of the compression tests, the grout was preserved in different conditions:

- atmospheric conditions;
- immersed in water extracted in the work site;
- below the soil of the excavation place.

During the passing time the visual verification of the properties was analysed. (*Table 22*)

The cylinders behave different for every preserving environment. The most damaged were those left in normal conditions. They lost their initial properties, with some degradation and disintegration. Instead, the samples preserved in water and soil conserved the consistency, especially the samples left in terrain, which were almost intact, with no change in volume or presence of fissures.

At least, the most adverse conditions for the durability are unreal in the tunnel excavation, because the grout layer is always confined. However, it will be important to determinate the causes of the degeneration, for warranting this conditions are not reproducible underground.

Moreover, the durability of the two component grout can be supported for the absence of data about decomposition or problems in the tunnels built in the past 10 years at Europe, with the application of this type of grout, or more significantly at Japan, where the method is been extensively used since 20 years ago.

- Water absorption test

For performing this test, the mixture samples were left curing under water until past 2 months, when they were mobilized to a place with humidity of 50% for 12 hours. Afterwards, the cylinders were weighed and preserved under water once again for 24 more hours. (*Figure 49*) Finally, the weight was measured another time and the absorption coefficient was estimated using the equation:

$$a = \frac{Weight_{DRY}}{Weight_{WET} - Weight_{DRY}} * 100$$

It was found that the average absorption was 12%, a usual value for this kind of material. Also must be considered the scale effect to this experiment, because the results depend on the exposed surface of the cylinder. Therefore, is probable to find higher values in situ.

TUNNELLING WITH FULL FACE SHIELD MACHINES: Study of the backfill of the tail void









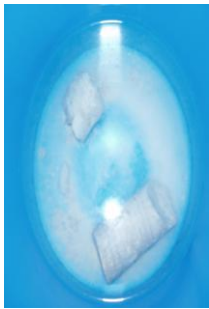

Sample	Curing Cond.	Initial State	After 7 days	After 28 days	Note
C1	Water				From Sample C1 have been extracted the cylinder 9
C2	Water				
C3	Air				
C4	Air				
C5	Soil w=40%				From Sample C5-C6 have been extracted the cylinders 12 and 13
C6	Soil w=40%				

Table 22 Durability Test Results.

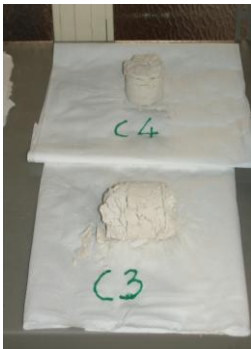
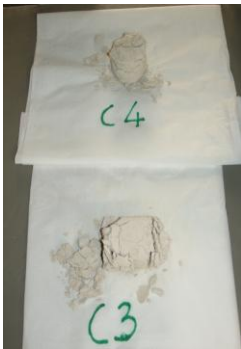

Figure 49 Water Absorption Test Sample (Cylinder 9). (Peila et al, 2008)

- Resistivity test

The electrical resistivity was measured on cylinders preserved in water for two months after the preparation of the grout. Then they were left 12 hours under water (humidity of the 100%) or in an appropriate place where the humidity was control in 50%.

They were electrodes situated in opposite directions of the sample, through which was transmit electricity (*Figure 50*). The obtained results were:

- sample kept in 50% of humidity: $\rho=20.4\Omega \cdot m$;
- sample kept under water: $\rho=65.9\Omega \cdot m$

The resistivity acquired was compared with literature, made in soils. The mortar reaches the proper resistivity for fine grain size material. Besides this, it can be concluded that the resistivity increase with the water absorption and this results can be taken into account as a base in the study of the integrity of the grout.



Figure 50 Resistivity Test execution (Cylinder 10) (Peila et al, 2008)

Sao Paulo Metro Line 4 Tests.

Additionally to the extensive range of experiments executed by the Politecnico di Torino, some information of laboratory tests made by Pellegrini et al (2009) in the construction of the Sao Paulo Metro Line 4 are also available.

The manufacturer established as optimal characteristics for the Component A and the grout the following:

- marsh Viscosity (4.7mm nozzle): from 35 to 45 seconds;
- bleeding:
 - after 1 hour: less than 0.5%
 - after 2 hours: less than 1%
 - after 24 hours: less than 4%
- initial setting time for the component A: Not present in the first 24 hours;
- gel time: from 6 to 12 seconds;
- compressive Strength:
 - after 1 hour: greater than 0.1MPa;
 - after 24 hours: greater than 0.5MPa;
 - after 28 days: greater than 2.5MPa.

It can be observed certain equanimity regarding the properties that are regulated by the suppliers, based on the same tests. The difference in the requirements might be legated to the variation of the project conditions.

Although they are not given explicit lineaments of the proceeding, it is specified the employment of the same standard tests for bleeding and viscosity of the component A. The results indicated the required properties were achieved.

Respect to the gel time, several experiments were done, using different proportions of accelerator component, until arrive to the gel time needed. The mixing process was made in plastic containers but there is no information about the assumption of the gelling moment (*Figure 51*). The gel time test results were found according to the proportion of the component B mostly composed of sodium silicate. The *Figure 52* reports the gel time suggested, and how the grout takes more time to turn into plastic state as the proportion of the accelerator increase.



Figure 51 Sample after during the gel time test (Pellegrini et al, 2009)

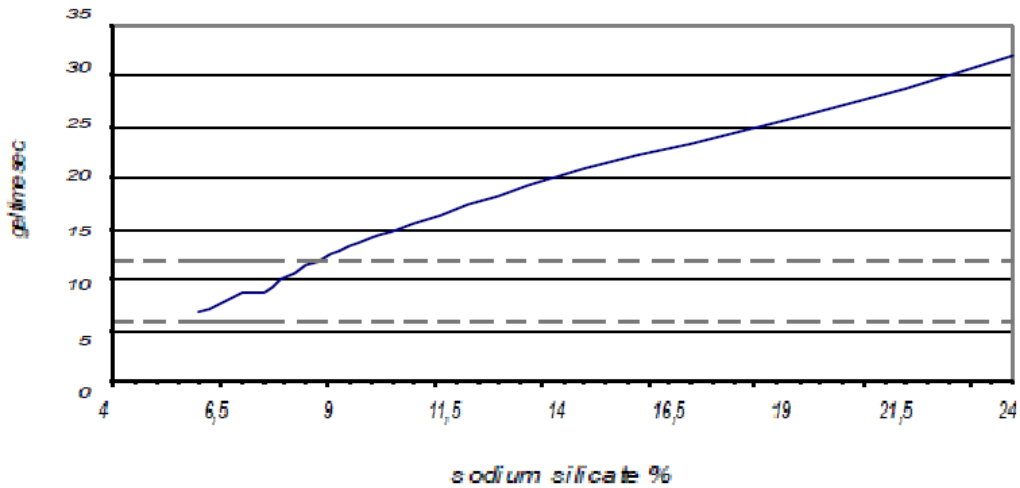

Figure 52 Relation between accelerator proportion and gel time. (Pellegrini et al, 2009)

An interest factor was the requirement of certain resistance after 1 hour of the preparation. Making a uniaxial compressive test is impossible to determine when the grout is not hardened, for that reason Pellegrini et al, 2009 have modified the Vicat apparatus, in order to study the gel strength (*Figure 53*).



Figure 53 Modified Vicat apparatus /0,1 MPa compressive strength is achieved.
(Pellegrini et al, 2009))

The standard Vicat needle test is usually used for determining the setting time of the concrete, introducing the needle, and measuring the deepness arrived. The no-standard method designed for this study has incorporated a weight jointed to the needle support, which allows it to apply 0.1MPa of pressure. The latter resistance was achieved by the grout when the apparatus was not able to penetrate into the sample (*Figure 53*).

The compression strength after 24 hours and 28 days was practiced as usual, with cubes of 100x100x100, curing at 20°C and humidity higher than 90%. The compressive strength obtained was:

- after 1 hour: >0.1MPa;
- after 24 hours: 0.7MPa;
- after 28 days: 3.8MPa.

CHAPTER 5

CHOOSING THE BACKFILL GROUTING SYSTEM

Every project has their distinctive needs, especially in this field of work; the geology can have infinite particularities, not to mention other conditions like location, dimension, political, economical and administrative issues, alignment, water presence, time requirements, etc. Moreover, the backfill grout technique is not widely studied, and there are many uncertainties associated to the mechanism that occur during and after injections, at least until the grout hardens. Because of that, the selection of the backfill method and material must be founded in their characteristics and the relation with the project situation. Generally, this is based on experience and monitoring.

The expected properties of the grout and its application are not standardised, making difficult the selection of the system. However some important topics have been object of study in the recent years, and have expanded the possible parameters in which base the grout selection.

Some important subjects to take into account are:

- ***Compressive Strength***

Based on the characteristics of the project, the needed compression strength is decided. The required amounts of resistance are not so restrictive, because the structural function of the grout is small; often it has to be similar to the surrounding ground. Normally the resistance at 7 days and 28 hours are demanded, as consequence of the standardisation of these values. Taking into account that early stage properties are those more important, it might be reasonable the requirement for the resistance at 8 and 24 hours as well.

The compression strength for inert mixes is generally low,

The resistance of the two component grouts can vary depending of the project. As it was observed previously the strength after 1 hour can arrived to 0.1MPa, while the resistance at 28 days can goes from 3 to 6MPa. (Pelizza et al, 2009)

The cement based mortars can achieve the largest compressive strengths, modifying the cement dosage. It is possible to reach 15-20MPa at 28 days or more, but it is not efficient or necessary.

The semi-inert mortars develop their resistance from the cement substitutes. Generally this does not arrive to large strengths. The compressive strength at 28 days is from 0.1MPa (Cairo Metro Line 2. Shirlaw et al, 2004) to 0.5MPa. (Linger et al, 2008)

- ***Buoyancy and Set Time.***

Depending on the hardening time of the mortar, the buoyancy factor can be important, and consequently the increase of the longitudinal moment. In the first stages the injection pressure dominates the movement of the lining, but after a couple of rings, as it was stated before, the injection pressure is not longer suffered for the support, and some buoyancy of the lining can be present because the grout is already fluid.

If the mortar settles too slowly, the quantity of rings being unsupported will be higher, and greater moments will be produced as consequence of the buoyancy.

In this matter, undoubtedly the more efficient kind of grout is the 2 component one. The grout is in a plastic state when the injection pressure has the control of the behaviour of the lining; and hardens rapidly enough before arriving to the buoyancy controlled zone. Besides this effect is lower for this type of grout, because is lighter than traditional mortars.

The studies have showed that the friction between lining and grout produce a counteracting force against the upward motion (Bezuijen et al, 2004). Based on this fact, the inert mortars are also advised to prevent the buoyancy, even when they have the longest setting time (12 to 16 hours). A good gradation

of the mortar, with presence of rounded and crushed materials, contributes with the correct functioning of the mix.

Instead, the cement based mortars are the most unfavourable type in this case. The cement creates a liquid film around the lining that results lubricating, and the friction decreased considerable, making the uplifting easier. For this particular type of grout the setting time must be carefully controlled. The average timing goes from 5 to 12 hours for the initial setting, with the possibility of being modified employing additives.

In addition, also the damage on the rings and the point loads are more frequent when the grout has large setting time. Subsequently, this phenomenon is much controlled for the two component grout.

- ***Pump System and Clogging***

The evaluation of the performance of the excavation process is hard to define. However Feddema et al (2001) have studied the execution of the Botlek rail tunnel, and compared the efficiency of the two components grout with the cement based mortar. It was separated the total time of the work in: non operational time (the time which is not employed in the boring or construction process) and the operational time. This division helps the characterization of the idle time regarding the grouting system. From this point two indicators were defined:

- effectiveness, which represents the ratio between the operational time and the total realisation time.
- efficiency, who express the production per unit of operational time.

The more significant factor related to the use of the time is the effectiveness, which represents the profitability of the system. For the two components grout the effectiveness obtained was 56% and for the normal grout was 59%.

The results indicated that both methods have almost the same productivity. Nevertheless is necessary to go deeper, because this is the conclusion of only one case, and the problem is quite complicated, influenced by many factors.

Also the idle time for both cement based system and two component grout, was detached, making possible the analysis of what are the issues that generate deletes and the appearance of optimisation resolutions. (*Figure 54 and Figure 55*) While the two component grout is very vulnerable in its pumping system, the cement based mortar has the biggest problems referring to the clogging and batching plant cleaning.

The advantage of the traditional mortar is probably that it have been used for years, and the operators have plenty expertise on its utilization. However, the two component grout is developing yet, and its future is very promising.

Moreover, it is necessary to execute other studies, and also include the diverse types of grouting substances. The inert mix, for example, can present

difficulty in been pump as consequence of a mistaken grain size distribution, and it is not infrequent the blockage on the pipes.

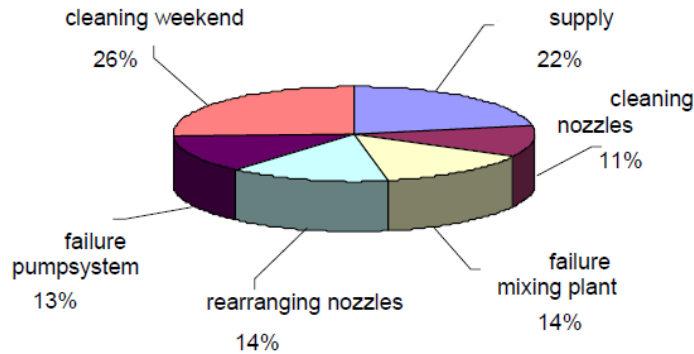

Figure 54 Distribution of idle time of two component system (Feddema et al, 2001)

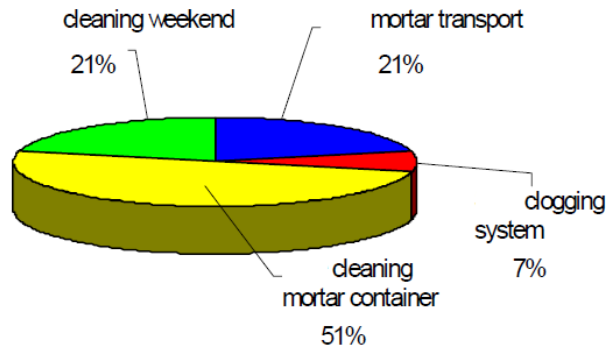

Figure 55 Distribution of idle time of traditional mortar grout. (Feddema et al, 2001)

- **Durability**

The backfill grout must guarantee the consistency in time, and must resist the water influence and the abrasiveness of the soil, without cracking, being eroded, or degraded. The design on this matter must consider many years, because the useful life of tunnels is generally long. The chemical stability of the concrete and inert mixes, is highly proved, not only in the tunnel employment, but the innumerable underground projects in which were utilized. Therefore, the durability of these types of mortars has been widely studied and already has been designed compositions against very abrasive conditions.

Related to the erosion in inert mixes, this must be considered prior the application of the grout and be taken into account for several design parameters. Usually some cement suspension is added in this type of grouts, contributing with the resistance to the washout.

The durability studies for two component grouts are still in its infancy. The stability within time is still on assessment, even when there is not information

about the bad functioning of the material, despite the method is been employed in Asia from 20 years approximately. It has been carried out a number of Japanese studies, but generally they are not available in English. The Thixotropic-gel Grouting Association has tested the behaviour of the compression strength in time, for the two component mix using different types of cement. The dosage used includes 90l of sodium silicate, and 230kg of cement and the samples were cured under water.

The resistance with Portland cement increase within 28 days, developing almost the same compression strength of the mixture with Slag cement. However, the mixture decreased its strength passing the days, and after 3 years it arrived to a value near to 1/3 of the original resistance. Inversely, the mortar made with slag cement showed a better performance, increasing and maintaining its mechanical properties in time. (Figure 56)

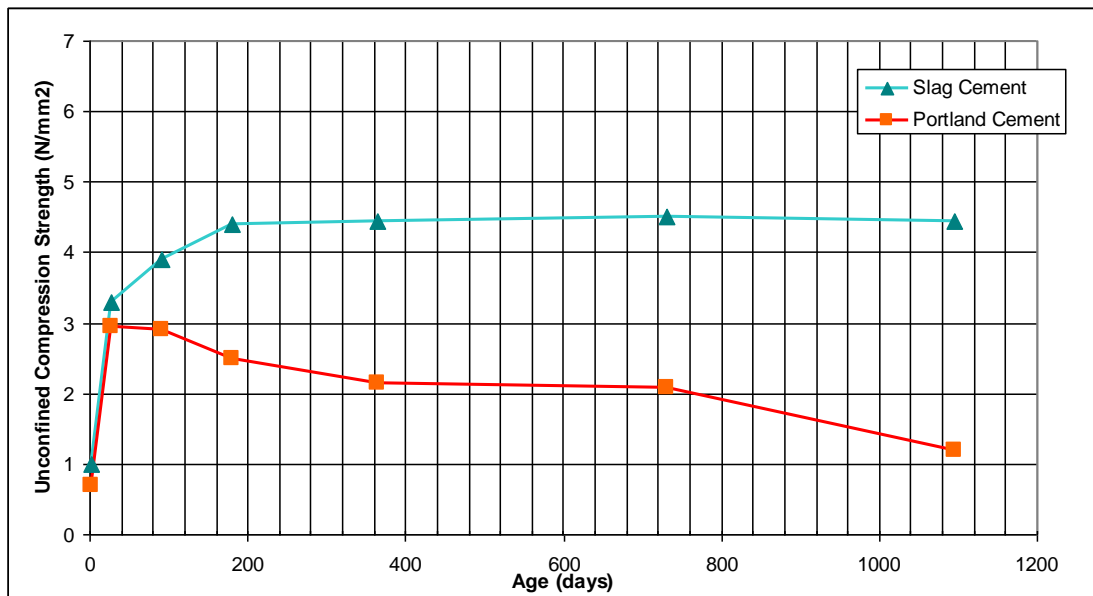

Figure 56 Slag Cement versus Portland cement behavior in time. (Thixotropic-gel Grouting Association)

Additionally, it was also tested the durability respect to the cement quantity, in samples cured under seawater. It was found the compression strength is directly proportional to the amount of cement in the mixture, and also the satisfactory behaviour of the Slag cement to the abrasiveness of the seawater (Figure 57).

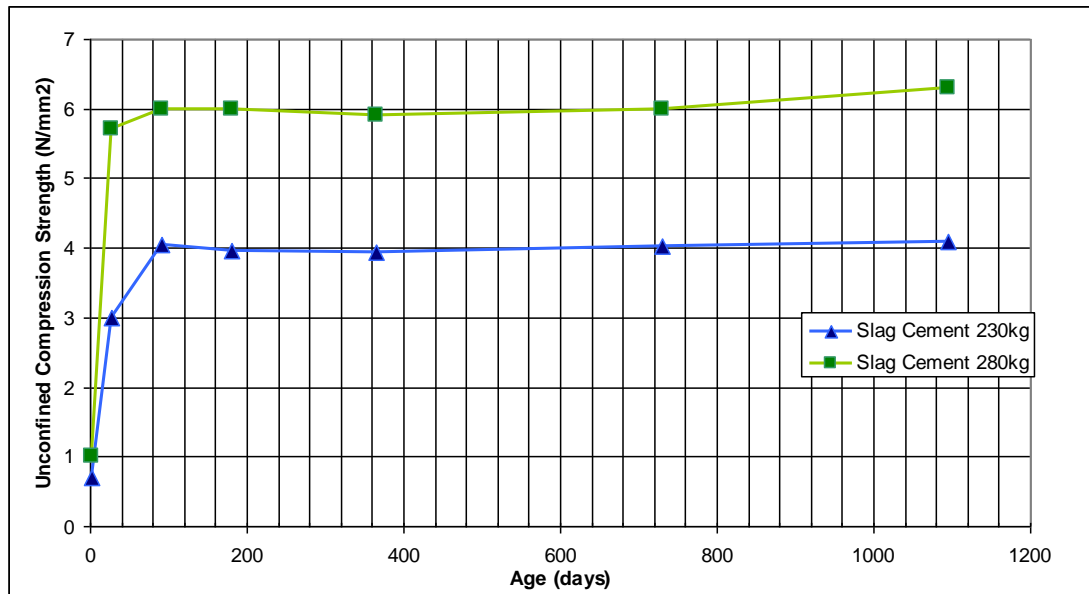

Figure 57 Behavior in time related to the quantity of cement. Slag Cement. (Thixotropic-gel Grouting Association)

In 2003 a series of tests were practiced on the work site of Portland, in United States, included a sample which was left in a natural atmosphere until 2008. The objective was to observe if the piece conserved the optimal characteristics or if it altered its properties. The *Figure 58* show the consistency remains the same, and no considerable defects were found.



Figure 58 Sample cured in constant humidity conditions by Portland after 5 years of its preparation (MAPEI UTT, Personal Information).

Additionally some rings were removed in the Singapore Metro excavation, when it was been build the intersection between an old and a new tunnel. The conditions of the grout (two component grout) were optimal and it was well stable in its position (Pelizza et al, 2009).

- ***Bleeding and Segregation***

Previously were commented the bleeding tests without or under pressure. The volume loss and segregation are highly related to the settlement control. The importance of this factor has in the entire project will determine the predominance of one method over the other, whether the tunnel is excavated in urban areas, or in inhabited zones.

The different studies revealed that all systems generate almost the same expulsion of water, although the two component grout was slightly slower. However, the real way to attack this problem is using the appropriate dosage, because, as it was observed, the maximum bleeding is established for the manufacturer.

- ***Economics***

The budget of the project can be a very restrictive factor, and the contractor searches the most convenient performance-cost relation.

The inert mixes are usually the less expensive because the cement represents a considerable proportion of expenses. Nevertheless, the cost and quality of the inert mixes is related to the closeness to the materials.

The cement based mortars can vary its costs in a wide range. This very versatile kind of grout can fluctuate from economical prices to very expensive ones, according with the additives, and resistance that it is necessary.

The two component grout is the most expensive one. This is by far its most unfavourable attribute.

However, it is important consider that sometimes grouting costs are related not only with the materials and equipment cost. The TBM excavation time lost due to grouting system problems can result in even greater cost increasing total expenses not indifferently.

CHAPTER 6

NUMERICAL SIMULATION

1. Settlements induced by tunneling and excavation process.

The excavation of the tunnel produces a relaxation of the initial tensional state, leading to deformations in the ground from certain distance beyond the excavation face. The convergence in the tunnel is the inward displacements of the soil as consequence of the relief of the initial stress. In case of no support the ground is free to deform into the cavity until arriving to the equilibrium state.

It is known that the deformations at the tunnel depth origin a chain reaction, transmitting the relaxation to the ground above it, being reflected as surface settlements in case of low overburden (*Figure 59*). The studies have discovered that the volume the ground takes inside the tunnel is related to the volume of moved ground in the surface, and in consequence to the settlements. Therefore the control of the subsidence is focused in avoiding the insertion of the ground into the tunnel by means of operational techniques during the tunnel construction.

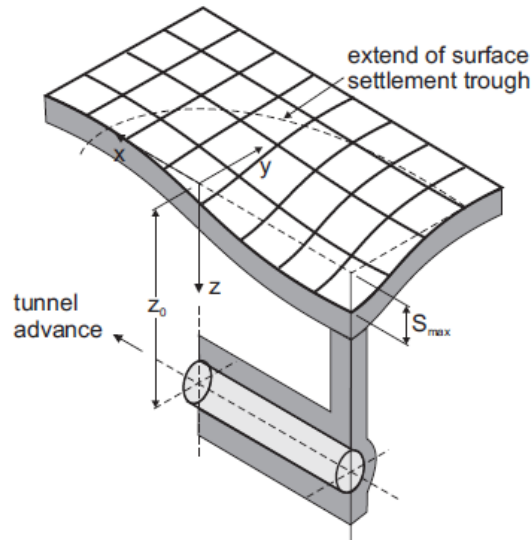

Figure 59 Tunnel induced settlements (Guglielmetti et al 2007) (Attewell et al, 1986)

The excavation process of the TBM initiates with the rotation of the head and the detachment of the ground as consequence of the cutters action.

The face pressure is executed against the front for guarantee the face stability. It can be reached by mechanical pressure, or using slurries or soil compounds. The force has to counteract the earth pressure and the water table, but must be lower than the vertical stress state, for preventing the risk of blow out. The amount of face pressure must be designed to avoid subsidence and to control the hydrologic conditions. According to the Centre Underground Bowen (COB)(Guglielmetti et al, 2007) the minimal face pressure recommended is:

$$\sigma_T = ka * \sigma'_v + \sigma_w + 20kPa$$

where:

σ_T : minimal face pressure;

ka : active pressure coefficient;

σ'_v : effective earth vertical pressure;

σ_w : water pressure.

The soil is taken away and the machine slightly moves forward push by the jacks, which use the just installed ring as toehold. To ease the advancement

normally is digged some volume beyond the diameter of the machine using the over-cutters, special utensils for this task.

When the jacks reach its maximum distance of elongation, the lining ring is assembled under the shield by the erector system, starting the process again.

During the advancement the lining under the shield starts going out, and the tail void is filled with grout, avoiding the relief of the ground.

The total surface settlements are composed by three components: the short term displacement, the movements related to the lining deformation and the long term settlements. (Guglielmetti et al, 2007) (*Figure 60*)

The short term settlements are caused by the excavation process. The deformations that initiate ahead the tunnel face and finish with the hardening of the grout correspond to the category, when the lining is responsible to inhibit further displacements.

Every part of the excavation process is related to some range of subsidence and to some operation to avoid it. The face stability has been widely studied, and the pressurized face machines provide the most controlled system to reach it. This type of machines uses different mechanisms to exert certain pressure upon the front, in order to avoid the relaxation of it, and subsequently deformations of the soil prior and during the excavation.

While the machine is excavating and the front relief is controlled, the walls are immediately supported by the shield of the machine. The gap remained from the overcutting and due to the tapering of the shield, can deform even until close it completely. These displacements are almost inevitable; depend of the relation between the rate of deformation of the soil respect to the advancement rate.

The injection of grout tries to control the additional deformation of the soil, but there is still some displacement in this phase, related to the time that takes to fill completely the void and the time that takes the grout to harden sufficiently to counteract the earth pressure.

If any of the excavation stages are carried out improperly, the deformations will be higher, with subsequently higher surface settlements. Although, the settlements can also be controlled with ground reinforcing techniques like: jet grouting, steel pipe umbrella, permeation grouting, compact grouting, etc.

Afterwards, the lining is in charge of the performance of the tunnel. Some deformations can be present when the support is not able to resist the loads and moments acting against it. This component of the total settlement is prevented with an accurate lining design process.

Finally the long term displacements are mostly related to cohesive soils, which take some time to dissipate the pore pressures and consolidate.

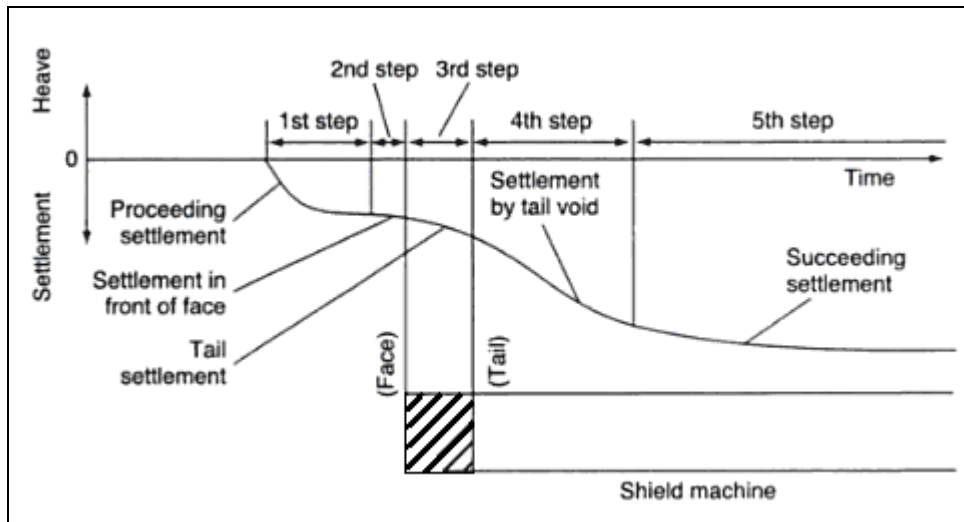

Figure 60 Causes and mechanism of ground displacement (Tatiya, 2005)

2. Empirical methods for subsidence estimation.

The distribution of these displacements has been studied extensively in the last 40 years, finding that the convergence inside the tunnel influences the rest of the soil, vertical and horizontally. The most common empirical method approximates the configuration of the transversal settlements to a Gaussian distribution. Schmidt (1969) and Peck (1969) studied some cases and associated the surface settlements in this direction to the Gaussian function: (Figure 61)

$$S(x) = w_{\max} \cdot e^{-\frac{x^2}{2i^2}}$$

where:

w_{\max} is the settlement above the tunnel axis;

x is the horizontal distance to the tunnel axis;

i is the horizontal distance to the point of inflection of the settlement curve.

Furthermore, the volume of the ground deformed inwards the tunnel, also called volume loss, was correlated with the volume of the subsidence V_s . Generally these volumes are expressed as a percentage of the total volume excavated per advanced distance. For pressurized face machines in sands and gravel, it was found that the volume loss was generally minor to 0.5%, instead for soft clays, the ground loss before the consolidation was from 1 to 2%.

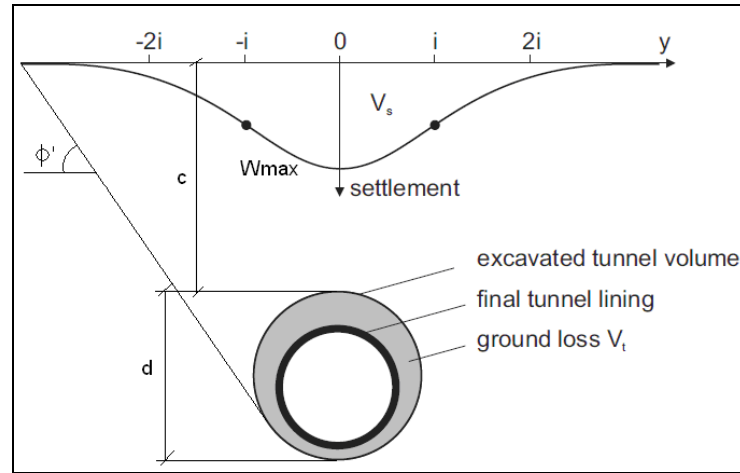

Figure 61 Gaussian curve for transverse settlement trough and ground loss V_t (Möller, 2006)

The volume of surface settlement per unit length of tunnel (V_s) can be calculated as the integral of the Gaussian distribution, obtaining: (Peila, 2009)

$$V_s = \sqrt{2\pi} \cdot i \cdot w_{\max} \cong 2.5 \cdot i \cdot w_{\max}$$

When the tunnel is constructed in undrained conditions the V_s must be approximately the same of the V_{loss} . However under drained ground, as dense sands, the V_{loss} can be lower than the V_s , because some dilation can be present as consequence of the unloading (Cording et al 1975). The relation of these two volumes has been roughly estimated as $V_s \cong 0,7V_{loss}$. Instead, in loose granular soil, or collapsible materials the V_s can be higher than the V_{loss} , produced by negative dilation. (Guglielmetti et al, 2007)

In order to establish a reference parameter to compare different projects, and due to the nearly linear dependency of the ground loss to the volume of the tunnel, it was determined the Ground Loss Ratio:

$$GLR = \frac{V_s}{A_t}$$

where A_t represents the cross-sectional area of the tunnel.

It was found that this ratio usually varies from 1 to 3% for conventional excavation (Peila, 2009) (Maidl et al., 1996).

Assuming the transversal settlements as a Gaussian distribution, New and O'Reilly (1991) approximated the longitudinal subsidence configuration to a cumulative probability curve. This method assume constant volume conditions, therefore is only accepted for cohesive soils. In addition Attewell and Woodman (1982) investigated the soil movement for open face excavations, finding that when the front arrives the settlement was nearly 50% of the total subsidence. However, in case of pressurized face machines, the deformation before the front

arrives is widely controlled and lower values are expected. Craig and Muir Wood (1978) also categorized the percentage of longitudinal settlement depending on the type of soil, based on cases studied in the United Kingdom. The influence of the tunnel process in the settlements can be observed in *Table 23*

Type of ground	Percentage of total settlement completed	
	At face of shield [%]	At passage of tail of shield [%]
Sand above water table	30-50	60-80
Stiff clays	30-60	50-75
Sand below water table	0-25	50-75
Silts and soft clays	0-25	30-50

Table 23 Development on settlement profile (Craig et al, 1978) (Möller, 2006)

The settlement control becomes so important in urban areas because the deformation of the ground can cause differential settlements in the foundations of the near buildings. The differential settlements and the rotations of the bases are restricted by normative. The settlements expected for the excavation of a tunnel must be set at the beginning (normally through the utilization of empirical methods) and correlated to the maximal permitted values. However these methods are referred to uniform types of ground. In presence of heterogeneous soils, the accuracy of the approaches decrease.

3. Problem solving with computational methods

The capacity of computers has risen in the past years. Every day the numerical methods become more important in all science fields, tunnelling is not the exception.

The geo-engineering is a challenging field for numerical methods because it involves many uncertainties. The analysis and designs of excavations must be achieved with relatively little information of the ground conditions, and the possibility of sudden changes in the deformability and strength properties. It is impossible to obtain complete field data at a rock or soil site.

Since the ground characteristics are insufficient, the numerical modelling must be used with attention. The first scope of the computational methods is to understand the phenomenon that influences the performance of the construction, for the subsequent use in the design process. Computational calculation has opened the opportunity of studying mechanisms on the tunnel that were previously unknown.

The study of the processes can be done through 2D or 3D methods, which are differenced on its complexity. The 2-dimensional technique is commonly used

because it is relatively simple against the favourable results that give. Instead the 3-dimensional codes are very complex, and require much time and computer capacity. 3D methods are recommended for the detailed understanding of the processes, and are frequently used in research.

Nowadays, 3D simulation of the mechanized tunnelling process is used to describe the interaction between soil-structure and machine. The recent back-analysis practiced has correlated this kind of computational scheme to the study of the settlements. This tool will permit establishing accurate methods for future estimation of the subsidence, in complicated conditions that are not considered in empirical analytical procedures.

For a not well studied process as the backfill grouting, the computational methods are used like a numerical laboratory, to test ideas.

In previous researches is been taken into account the influence of the backfilling in the tunnel development. Generally the injections were modelled as distributed loads at early stages, in order to reproduce the influence of the injection pressures. Normally they acted for some rings, being removed or replaced by continuous elements to which were assigned: the soil properties (Hoefsloot F et al, 2005); the harden grout mechanical features (Möller, 2006 and Castellanza et al, 2005) or even not considered at all (Drury, 2003).

3.1 Three-dimensional modelling of the backfill grouting

The present model is done with the aim of analyzing the influence of the backfill injection on the TBM process, also regarding other issues that can affect the development of the excavation. It will be differentiate the two component grout and the traditional cement based grout, and the evaluation of their performance.

The project consists in testing a regular situation of tunnel excavation using a shield machine with the face under pressure. It is assumed the advancement of an EPB machine in a granular soil, uniform all over the depth, above the water table.

The tunnel dimensions and the soil properties are been selected arbitrarily, as close as possible to the reality, and based on the Turin metro case. The geometry parameters are shown in *Table 24*

Tunnel Geometry	
Overburden (m)	30,70
Tunnel Diameter (m)	8,60

Lining Width (m)	0,30
Grout Width (m)	0,07
Shield Width (m)	0,05
Shiel Length (m)	9,00
Over cutting (m)	0,02

Table 24 Geometry parameters

3.2 Mesh and boundary conditions:

The initial step for the simulation is creating a representative volume of ground, which size must be decided large enough to avoid the influence of the boundary conditions to the model. It was used a section of 60x80x70m (*Figure 62* and *Figure 63*). The dimension is been planned such that the distance from the tunnel to the border is higher than 6 times the tunnel diameter in the x and y direction, and superior to 3 times the diameter below the tunnel (z direction). Because it is a shallow tunnel, the complete overburden is been considered.

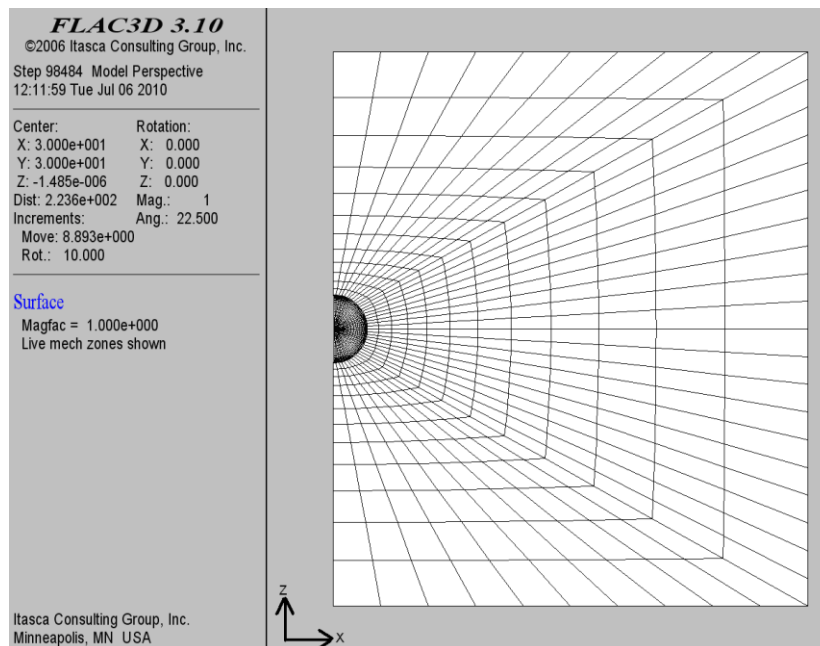

Figure 62 Front view and meshing

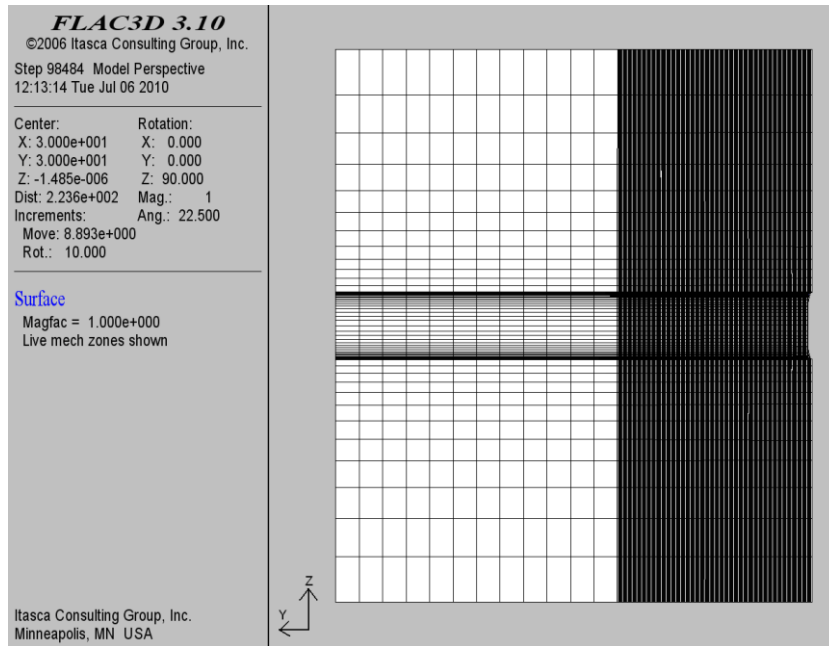

Figure 63 Lateral view and meshing

The ground fragment has restricted movement in the boundary planes as observed in *Figure 64*. The y -displacement has been impeded for the planes $Y=0$ and $Y=80$. As well the x -displacement has been limited in the planes $X=0$ and $X=60$, and finally the z -displacement is been constrained in the plane $Z=-35$. The surface was left free.

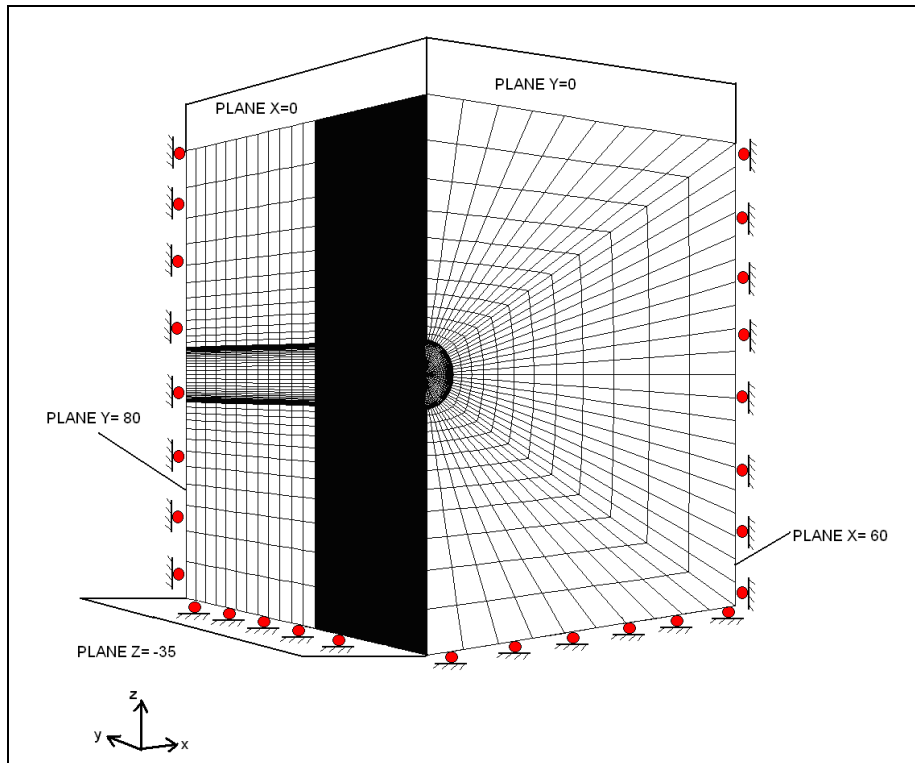

Figure 64 Boundary conditions of the model

The mesh is the established division of the model, which is the base of the number of iterations, and therefore the accuracy of the simulation. Using a mesh

too concentrated can be traduced in excessive time of calculation. However, too low mesh can lead to inexactness. Then, it was decided to apply a strong mesh in the tunnel vicinities and make it wider as the zones were getting away from the object of study. Regarding the particularities of the program, it is been necessary to use a very small zone dimension on the Y-direction. The model is formed by 328.960 zones and a total of 338.754 grid points.

In order to minimize the calculation time, it is been modelled just one half of the tunnel, according to the symmetrical behaviour of the excavation.

3.3 Material properties

The material constitutive model determinates the behaviour of the elements. There are many models available but the most employed is the Mohr-Coulomb (*Figure 65*). This contemplates a simple and effective way of describe the response of the geo-engineering materials, and its parameters are commonly accessible by laboratory or in situ tests.

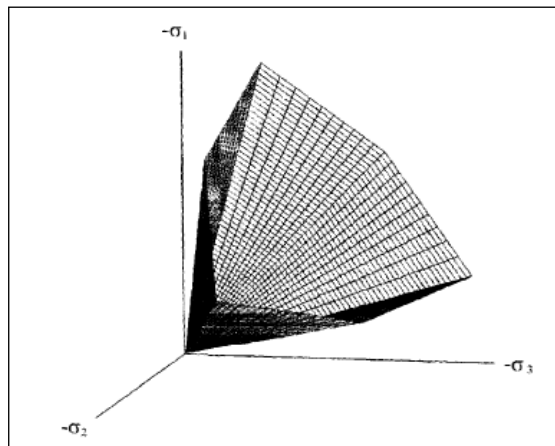

Figure 65 Three-dimensional Mohr Coulomb Model

To characterize the ground four parameters were established: the bulk modulus (K), the shear modulus (G), the cohesion and the friction angle. Usually to characterize the soil are used the Poisson (ν) coefficient and the Elastic Modulus (E); therefore from this values and through the following formulas were established the input properties: (Itasca Inc, 2006)

$$K = \frac{E}{3 * (1 - 2\nu)} \quad G = \frac{E}{2 * (1 + \nu)}$$

The selected soil parameters are in *Table 25*

Soil Parameters		
Specific Weight	γ (KN/m ³)	19,00
Cohesion	C (kPa)	4,00
Friction Angle	ψ (°)	30,00
Young's Modulus	E (MPa)	400,00
Poisson Coefficient	ν	0,30

Table 25 Soil Parameters

3.4 Considered construction aspects and construction phases:

For the elaboration of the three dimensional model is necessary to establish a strategy. This kind of model may be complicated because of the great quantity of details that are involved. The construction aspects that will be taken into account must be weighted based on the accuracy with they can be modelled, the effect that they might have in the situation and the desired level of detail.

There were considered two different grouting system: two component grout and traditional mortar. The goal of this analysis is to assess the construction of the same tunnel but with different grout method.

A method in which the excavation is simulated step by step was used. The tunnel is divided in slices of 0,5m, changing the conditions in every stage, in order to model the advancement of the machine. The total length of the project was 24m, for a total of 48 stages. The grid zones were grouped in: tunnel zones, overcutting zones and grout zones (*Figure 66*).

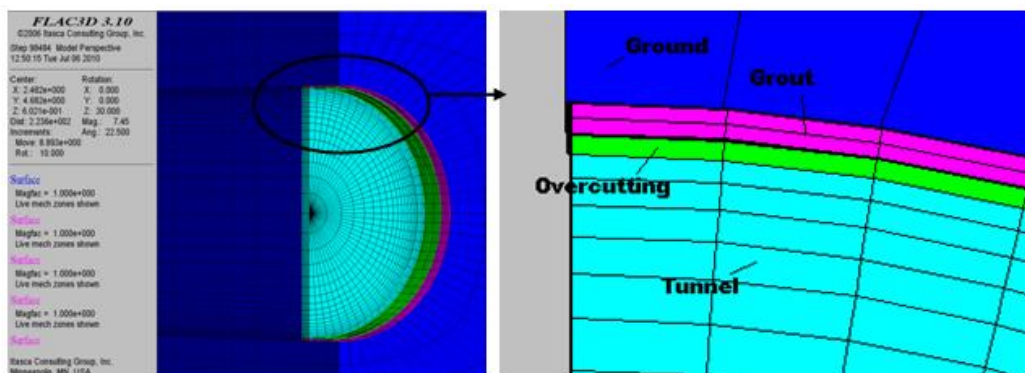

Figure 66 Zones distribution of the model

The 3D model was developed based in the following scheme:

The firsts 18 stages were dedicated only to the insertion of the machine into the soil. The same procedure was followed for every slice till the shield of the machine was completely into the model.

- Stage 1:

For the first stage the excavation of a 0,5m slice was simulated; the face and part of the shield of the machine was introduced into the model. Aspects as the face pressure, the overcutting and the temporary support of the shield were considered (Figure 67).

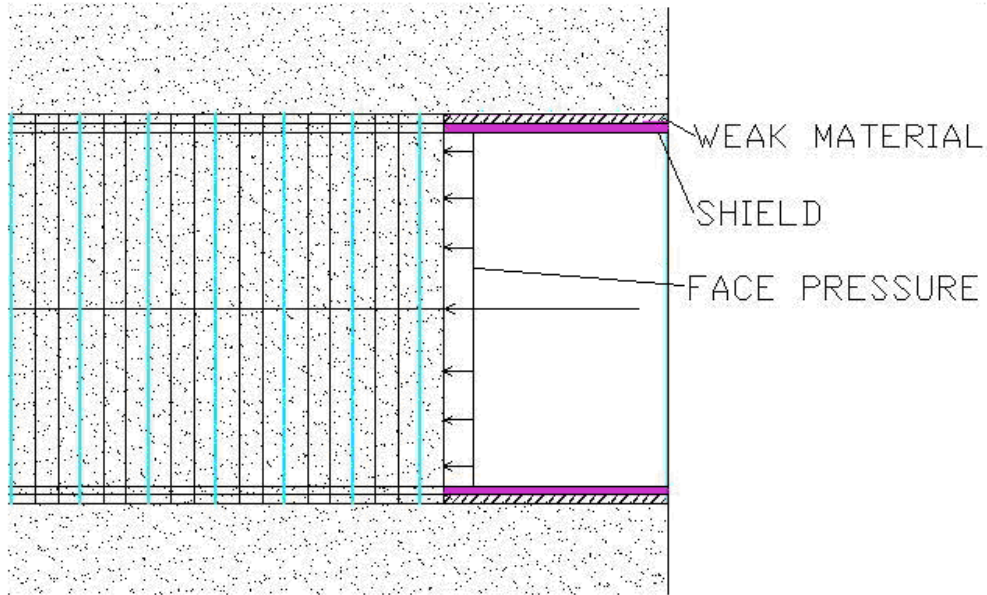

Figure 67 Stage 1 scheme

The tunnel zones were annulled for representing the dig of the machine and it was applied the face pressure against the subsequent section. The face pressure is calculated as the overburden pressure at the crown multiplied by the lateral active load coefficient (K_a) plus 0,2 bars (Table 26). The density of the muck in the excavation chamber was not considered.

Input Pressures	
Face pressure (kPa)	338
Initial Injection Pressure (kPa)	388

Table 26 Input pressures

At the same time were activated the shield elements. The shield is modelled as shell elements, namely flat elements structurally designed to resist normal and bending loading. These sections have isotropic and elastic

behaviour, and displacements caused by transverse-shearing deformations are neglected. The properties of the shield elements are shown in *Table 27*.

Shield Parameters	
Young's modulus (MPa)	210000
Poisson Coeficient	0,3
Specific Weight (kN/m3)	78

Table 27 Shield Parameters

The shear stresses produced by the shield-ground interaction were neglected, since the shield is modelled with this type of element. Even so it seems to have small impact on the surface settlements.

As it was studied previously, the overcutting and tapering of the shield have important influence on the surface settlements, being necessary to consider them. There is not realistic way of modelling the overcutting. The numerical systems do not permit the reproduction of the eccentric position of the machine and the appearance of the gap in the crown of the tunnel. Moreover, the shell and zone elements must always be in contact with other zones, so the independence between shield and ground is also impossible to reach.

Therefore, the mechanical characteristics of a soil layer around the shield were gradually decreased, creating an “almost” null zone. The new properties were decided iteratively to reach the overcutting amount, previously fixed in approximately 2cm.

The jacking forces were not taken into account.

- Stage 2-18:

The stage 1 is reproduced for the successive slice for stage 2, following the same procedure with the subsequent sections until the insertion of the shield of the machine is complete (9m, 18Stages of 0,5m each).

After stage 18 the excavation continues in the head of the model as usual, but also are taken into account some changes to simulate the construction of the support and the backfill process. Therefore two different procedures, for cement based mortar and two component grout were distinguished.

3.4.1 Traditional Mortar

- Stage 19:

The shield elements of the first slice were removed and the grout elements, the grout pressure and the lining were activated.

The backfill grouting layer is formed by the grout zones and the overcutting zones, which assume the properties of the grout after the shield move forward. The lining was also modelled with shell elements. The length of every ring was set in 1,5m and it is considered the time of excavation plus assembling of the ring in 1,5hours. A universal shape for the lining was selected. The presence of the gaskets has lowered the resistance of the rings that it was taken into account decreasing the elastic properties of the shell elements based on the Japanese Tunnelling Association approach. The lining properties are exposed in *Table 28*

Lining Parameters	
Young's modulus (MPa)	37000
Poisson Coefficient	0,23
Specific Weight (kN/m3)	24

Table 28 Lining Parameters

The grout pressures were simulated as a distributed load acting upon the ground and lining (*Figure 68*); for this stage it was used the initial value, estimated as the front pressure plus 0,50 bar: 388kPa.

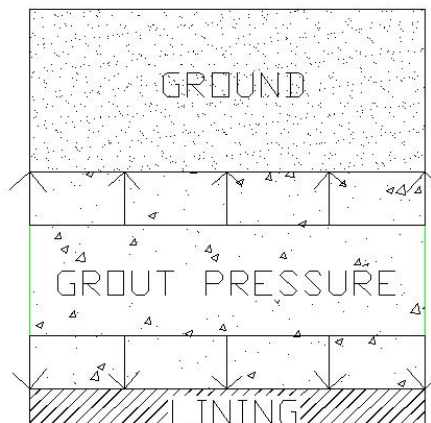

Figure 68 Grout Loads

The cement mortar properties were estimated following the information presented by Boumiz et al, (1996) about the development of elastic modulus and Poisson coefficient of the concrete ($w/c=0,4$) at early stages (*Figure 69*). The amounts assumed were lowered in a 40% respect to the article values, considering the loss of volume of the concrete and the adverse conditions

properties in the tunnel. For this stage the concrete was considered fluid, with elastic modulus of 8MPa, and Poisson coefficient of 0,49. The sketch of the stage 19 is showed in *Figure 70*.

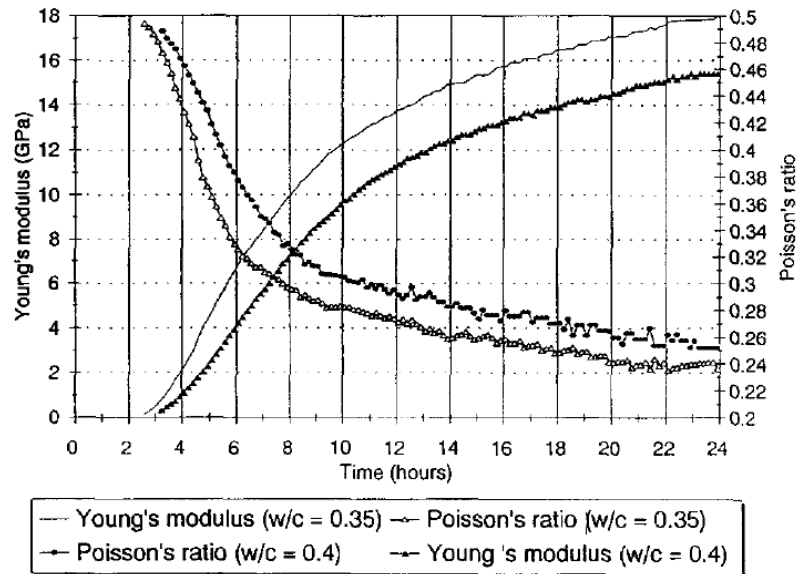

Figure 69 Concrete behaviour at early stages. (Boumiz et al, 1996)

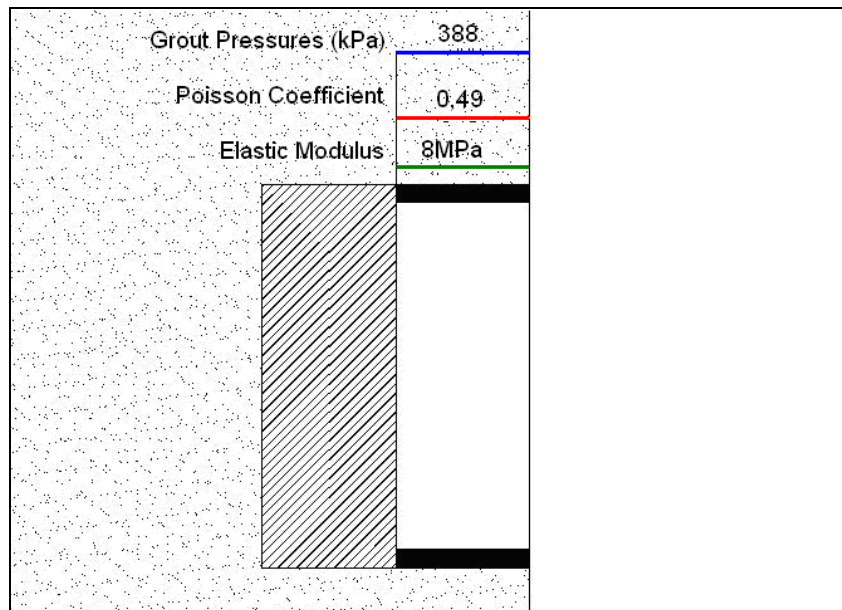

Figure 70 Stage 19 scheme

- Stage 20:

The excavation advance one more slice and the procedure of the Stage 19 is repeated in slice2:

- there were removed the shell elements;
- there were activated the grout zone elements;

- the overcutting zone elements take the grout properties (mentioned in Stage 19);
- the lining is applied;
- and the grout pressure is inserted.

In addition, the slice1 properties were also modified, to simulate the second part of the first ring, 0,5m farer from the machine. It was assumed that the grout pressure decreased, in order to model the standstill time and the distancing of the machine. The grout load was reduced to 373kPa. Furthermore, based on the excavation and assembling time, the concrete will have the same characteristics of the Stage 19 for the fists 2 rings, until the Stage 25. The progress of the TBM for this stage is represented in *Figure 71*.

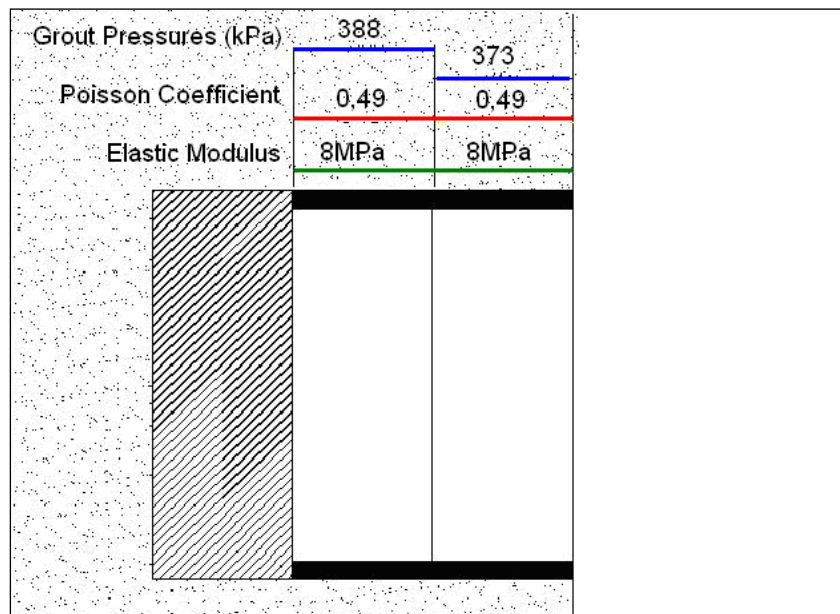

Figure 71 Stage 20 scheme

- Stage 21:

The slice3 takes the previous slice2 properties, the slice2 adopt the slice1's, and the slice1 change the injection pressure to 358kPa, continuing with the same mortar properties (*Figure 72*)

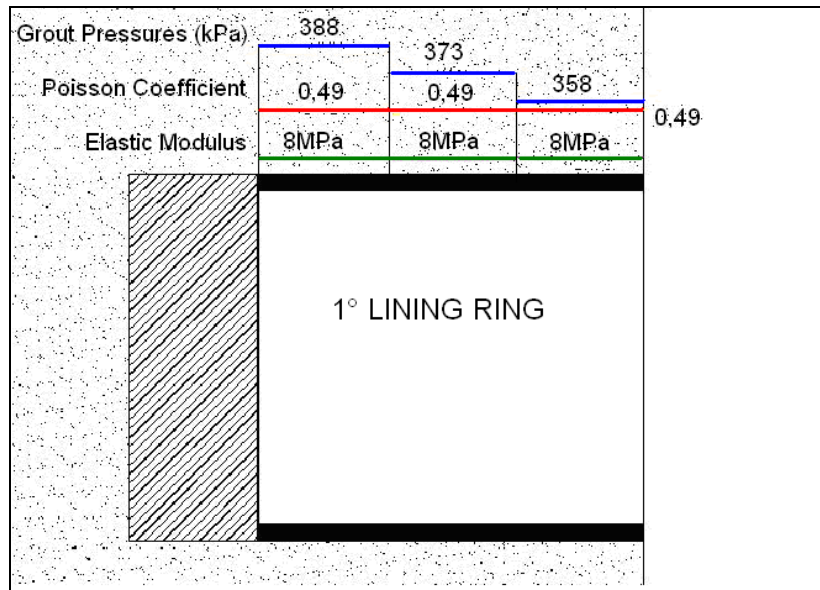

Figure 72 Stage 21 scheme

Stage 22:

The progression of the parameters on the slices was maintained, but this time the grout pressures were increased again, in order to reproduce the influence of the injection in the following ring. The value is fixed in 378kPa. (Figure 73)

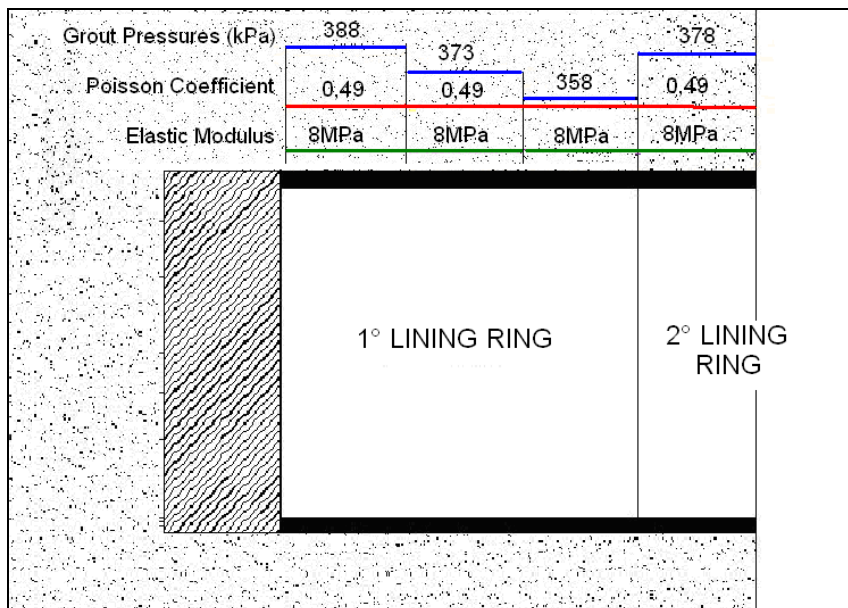

Figure 73 Stage 22 scheme

- Stage 23 and 24.

The load exerted by the mortar was reduced again, for the same purpose than before. At the stage 23 (Figure 74) the pressure was declined to 355kPa. The final part of the second ring was modelled in stage 24, arriving to 338kPa of grout pressure (Figure 75).

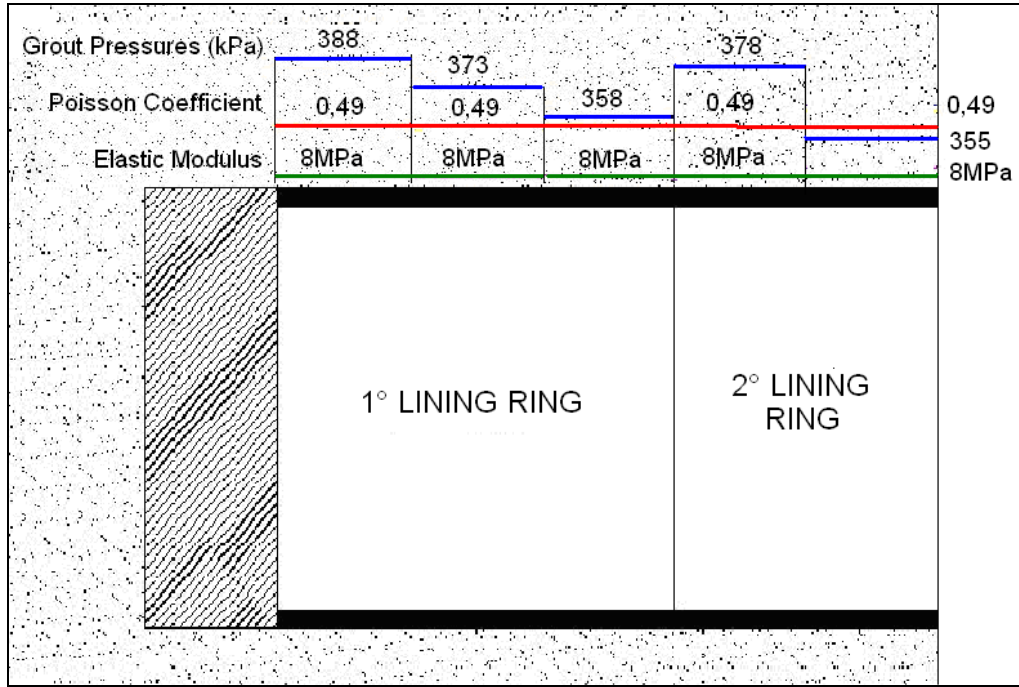

Figure 74 Stage 23 scheme

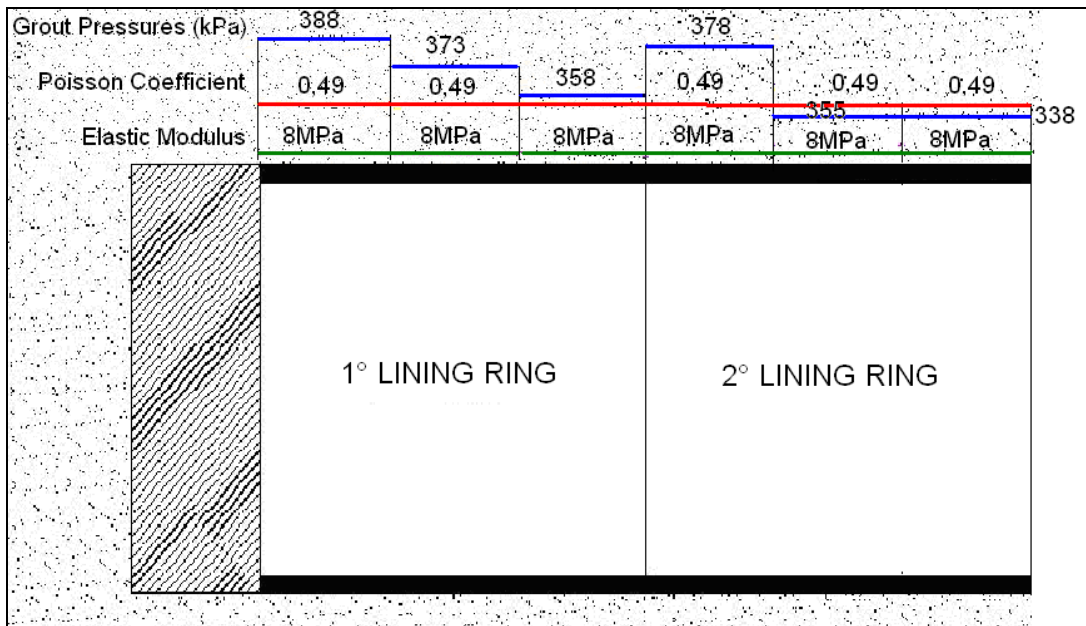

Figure 75 Stage 24 scheme

- Stage 25:

Following the investigations made by Bezuijen et al, (2004) and Hashimoto et al (2009) the injection pressure influence the grout and the lining after 5 to 7 rings passed. However, this pressure change is small and is taken as not relevant in the present model. Consequently, the grout pressures are permanently removed.

Recapitulating, the injection pressures were changed according to the slice distance from the tail, following the behaviour showed previously. The grout loads were applied until the second ring, when it is considered its influence could be neglected. For the first ring, starting with the initial magnitude, they were gradually decreased. However, when the second ring arrived, the pressures were increased again, and finally they were decreased until the face pressure value, being removed (*Figure 76 and Table 29*).

		Dist. from the tail (m)	Pressure (kPa)
1° Ring	1° Part	0	388
		0,5	388
	2° Part	0,5	373
		1	373
	3° Part	1	358
		1,5	358
2° Ring	1° Part	1,5	378
		2	378
	2° Part	2	355
		2,5	355
	3° Part	2,5	338
		3	338

Table 29 Grout Pressures Strategy

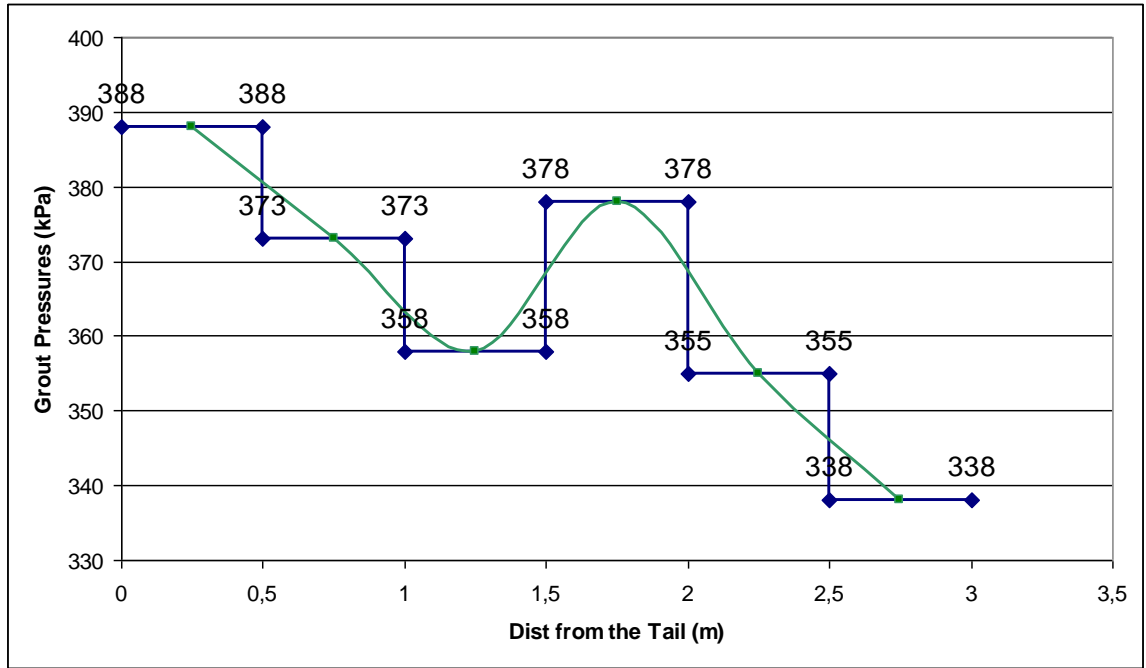

Figure 76 Variation of the grout pressure with the distance than the machine

The concrete was assumed to reach some resistance as consequence of the consolidation and while the machine goes forward the mortar is developing its mechanical properties. Hereafter the properties of the mortar will be changed for every ring as is showed in Table 30 and Figure 77 and Figure 78.

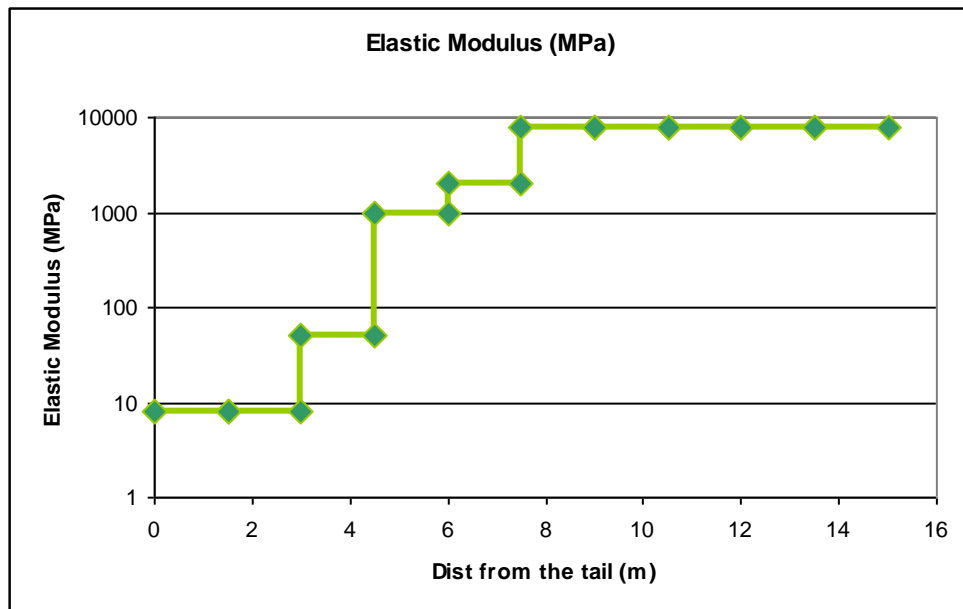

Figure 77 Evolution of the elastic modulus with the distance than the machine

	Dist. from the tail (m)	E (MPa)	ν
1° Ring	0	8	0,49
	1,5	8	0,49
2° Ring	1,5	8	0,49
	3	8	0,49
3° Ring	3	50	0,49
	4,5	50	0,49
4° Ring	4,5	1000	0,47
	6	1000	0,47
5° Ring	6	2000	0,43
	7,5	2000	0,43
6° Ring	7,5	8000	0,3
	9	8000	0,3
7° Ring	9	8000	0,3
	10,5	8000	0,3
8° Ring	10,5	8000	0,3
	12	8000	0,3
9° Ring	12	8000	0,3
	13,5	8000	0,3
10° Ring	13,5	8000	0,3
	15	8000	0,3

Table 30 Evolution of the mechanical properties of the grout

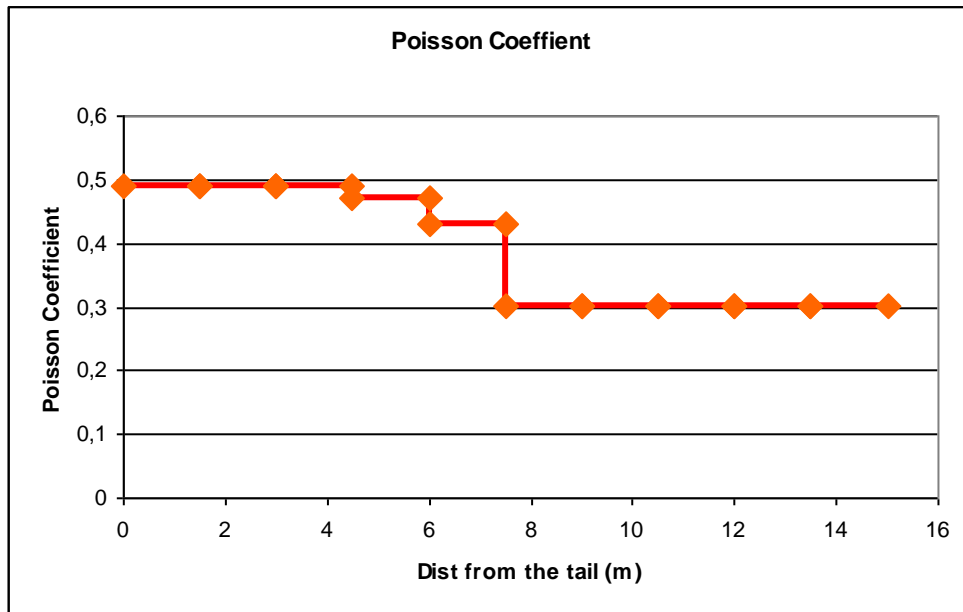

Figure 78 Evolution of the Poisson coefficient with the distance than the machine

The *Figure 79* shows a scheme of the stages of the model.

3.4.2 Two Component Backfill Grout:

For the simulation of the tunnel with two component grout, the geometric, lining and pressure parameters were assumed the same, but the grout properties were modified in order to simulate the different behaviour between traditional grout and two component one.

The young modulus and the Poisson ratio of the two component grout are not completely known in plastic state.

The two component mortar has the specific behaviour of become a gel some seconds after its application, and initiates to develop resistance after 30 minutes. In this work it was assumed that the two component grout resistance after it is completely harden is the same of the soil, but with higher Poisson coefficient, because it is basically formed by water. The material was modelled initially as a fluid and during the advancement of the first ring its resistance increase, being harden from the second ring on (*Table 31*).

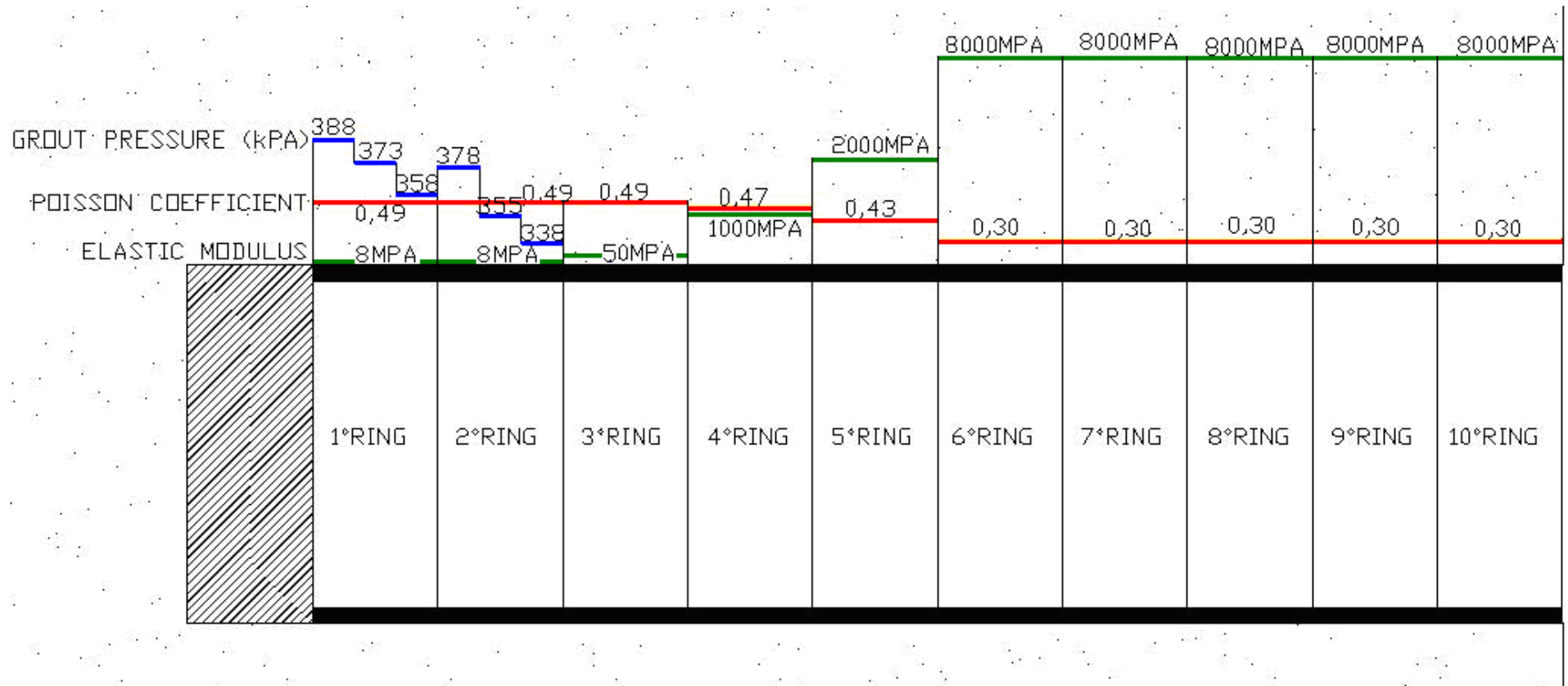

Figure 79 Model strategy: pressures and grout properties

		E (MPa)	v
1° Ring	1° Part	5	0,49
	2° Part	120	0,48
	3° Part	270	0,46
2° Ring	1° Part	400	0,45
	2° Part	400	0,45
	3° Part	400	0,45

Table 31 Two Components properties evolution

3.4.3 No backfill grouting considered:

In order to establish a base case, it was modelled the tunnel construction without the influence of the injection pressures and the grouting material. It was used the same principle for simulating the overcutting: they were assigned low resistance properties to the grout and overcutting zones, that allow the soil to deform, modelling the behaviour of the tunnel if the annular gap remained open.

3.5 Obtained results:

The total displacements and Z-displacements of the grid zones for the traditional grout case are reported *Figure 80* to *Figure 83*.

As expected the greatest displacements occur at the tunnel crown, dissipated towards the surface, but inducing little subsidence.

The deformation initiates ahead of the excavation face, but it can be seen that the chosen face pressure value was effective, because these displacements are small. On the other hand, inside the tunnel the transversal deformation is modest in the vicinity of the tunnel face and increase gradually as the machine advance, especially in the upper part of the cavity.

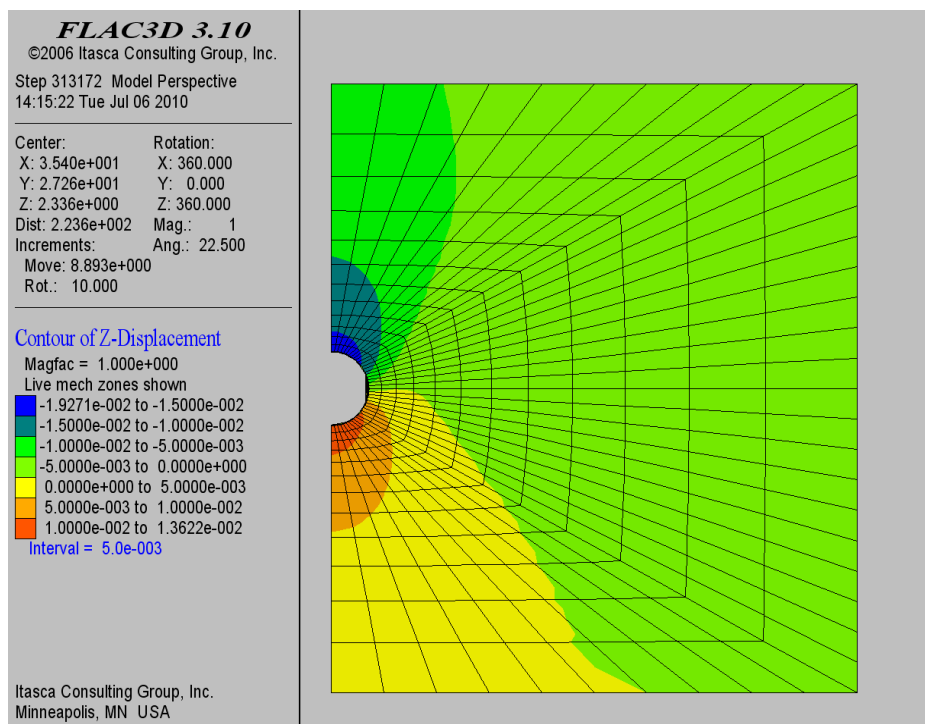

Figure 80 Z-displacement for traditional grout case. Frontal view

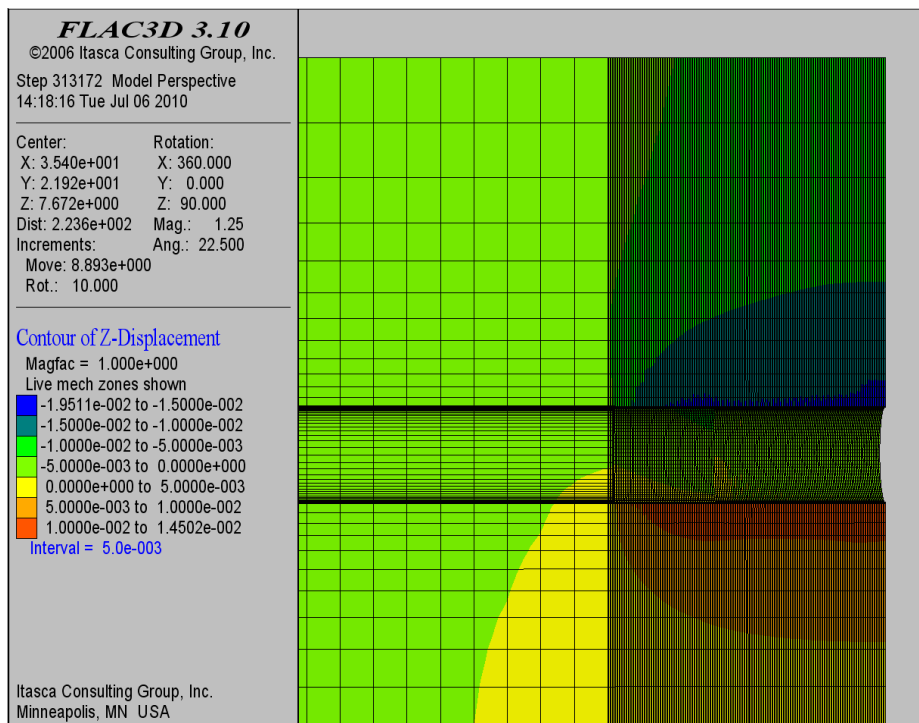

Figure 81 Z-displacement for traditional grout case. Lateral view

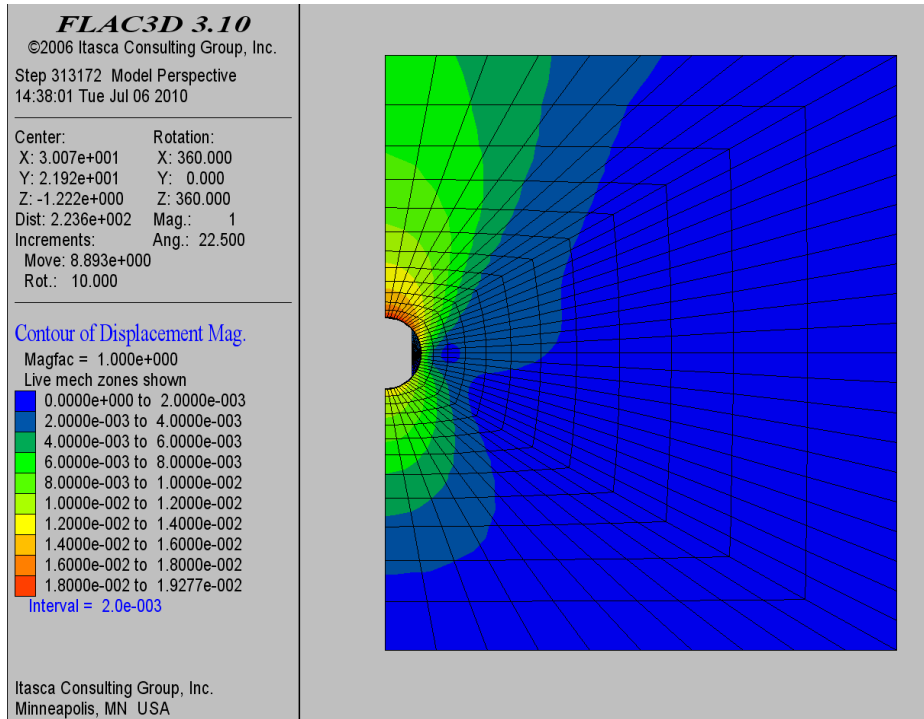

Figure 82 Total displacements for traditional grout case. Frontal View

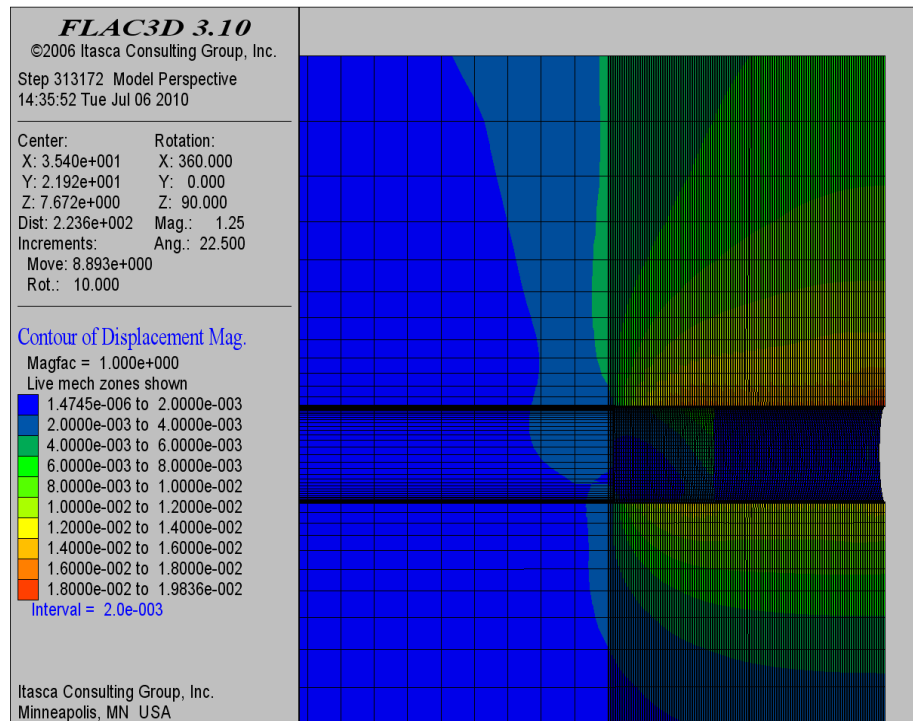

Figure 83 Total displacements for traditional grout case. Lateral View

3.5.1 Traditional grout

3.5.1.1 Transversal Subsidence:

The maximum settlement for the traditional mortar model is 6,7mm and the configuration of the subsidence is reported in Table 32 and *Figure 84*, showing the settlement progress in relation with the distance from the face ($y=24m$).

The transversal subsidence presents a Gaussian shape as expected than the theory. (Peck,1969)

Based on the earlier studied formulas (Peila, 2009), it was calculated the relation between the volume loss inside the tunnel and the volume of the normal curve constituted by the settlements.

The ground loss into the cavity was calculated using the average deformation between the crown, the walls and the bottom for the tunnel length.

The volume loss inside the tunnel numerically calculated is 0,50% and the V_s is approx 0,64 V_{loss} . The ground loss ratio (GLR) calculated is therefore 0,32%.

TUNNELLING WITH FULL FACE SHIELD MACHINES: Study of the backfill of the tail void

PLANE Y=0		PLANE Y=12		PLANE Y=24		PLANE Y=60	
X-coord (m)	Zdis (mm)	X-coord (m)	Zdis (mm)	X-coord (m)	Zdis (mm)	X-coord (m)	Zdis (mm)
0	6,7	0	6	0	4	0	0,475
6	6,2	6	5,5	6	3,515	6	0,43
12	5,15	12	4,5	12	3	12	0,39
18	3,85	18	3,45	18	2,21	18	0,33
24	2,65	24	2,38	24	1,605	24	0,23
30	1,803	30	1,61	30	1,18	30	0,19
36	1,2	36	1,08	36	0,79	36	0,15
42	0,79	42	0,705	42	0,5	42	0,1
48	0,535	48	0,47	48	0,35	48	0,075
54	0,415	54	0,375	54	0,27	54	0,055
60	0,37	60	0,345	60	0,24	60	0,035

Table 32 Transversal Subsidence for Traditional grout case

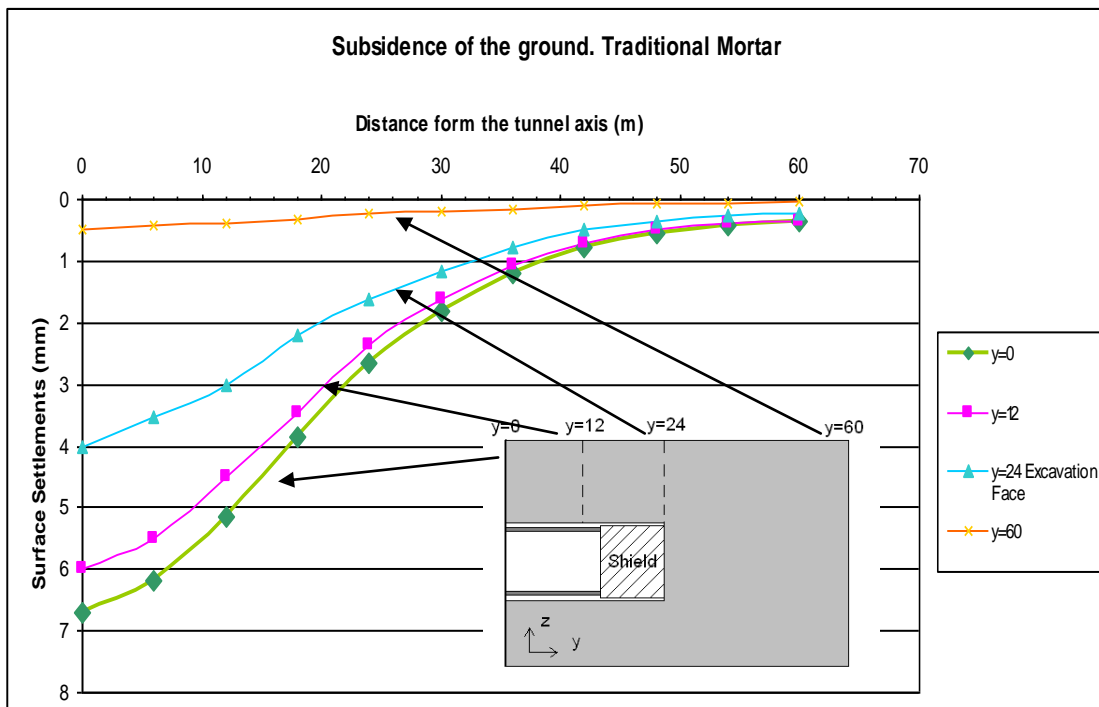

Figure 84 Subsidence diagram for traditional mortar case

3.5.1.2 Longitudinal subsidence:

The displacements in correspondence with the tunnel axis were monitored. The longitudinal settlements are shown in *Figure 85*. The line with the squares represent the location of the face, where is found 3,95mm of subsidence (59% of the total settlement). Moreover, the line with the triangles illustrates the tail of the machine, with 5,5mm of surface displacement (82% of the total). The percentage of deformation after the passage of the TBM was almost the 18% of the surface settlements.

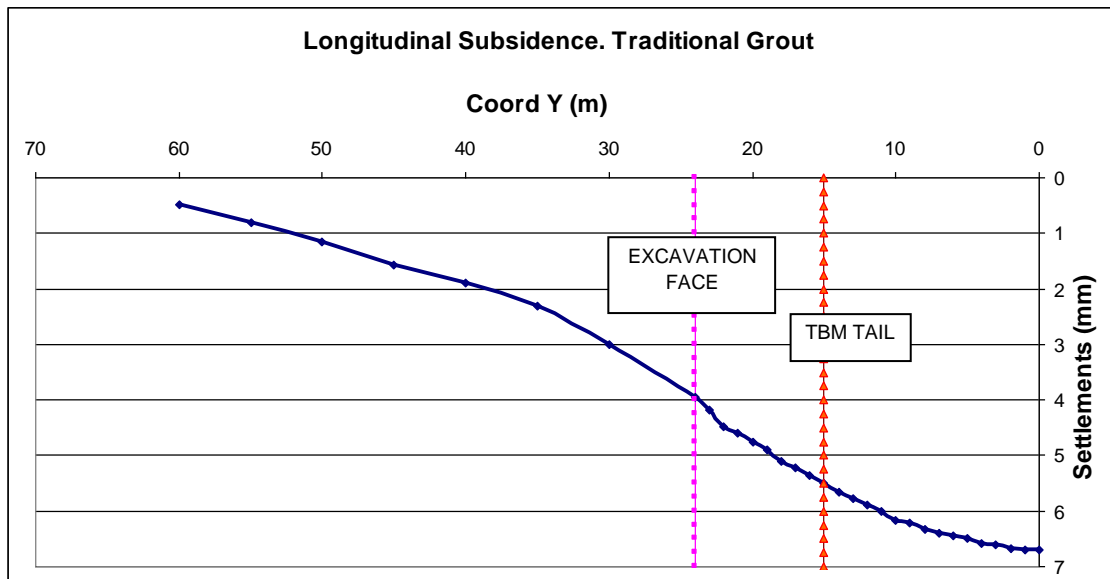

Figure 85 Longitudinal subsidence. Traditional grout

3.5.1.3 Longitudinal Deformations inside the tunnel

The behaviour of the ground at the crown and at the bottom of the tunnel is showed in *Figure 86* and *Figure 87*. When the machine excavates the ground, there is already present some deformation of some millimeters, that increase with the passage of the machine, as consequence of relief permitted by the overcutting. The maximum deformation is just before the injection initiates, after that the soil is compressed by the grout pressures. Past a couple of rings the grout pressures do not influence anymore the tunnel, the displacements equilibrate, and thank to the grouting process they do not increase anymore.

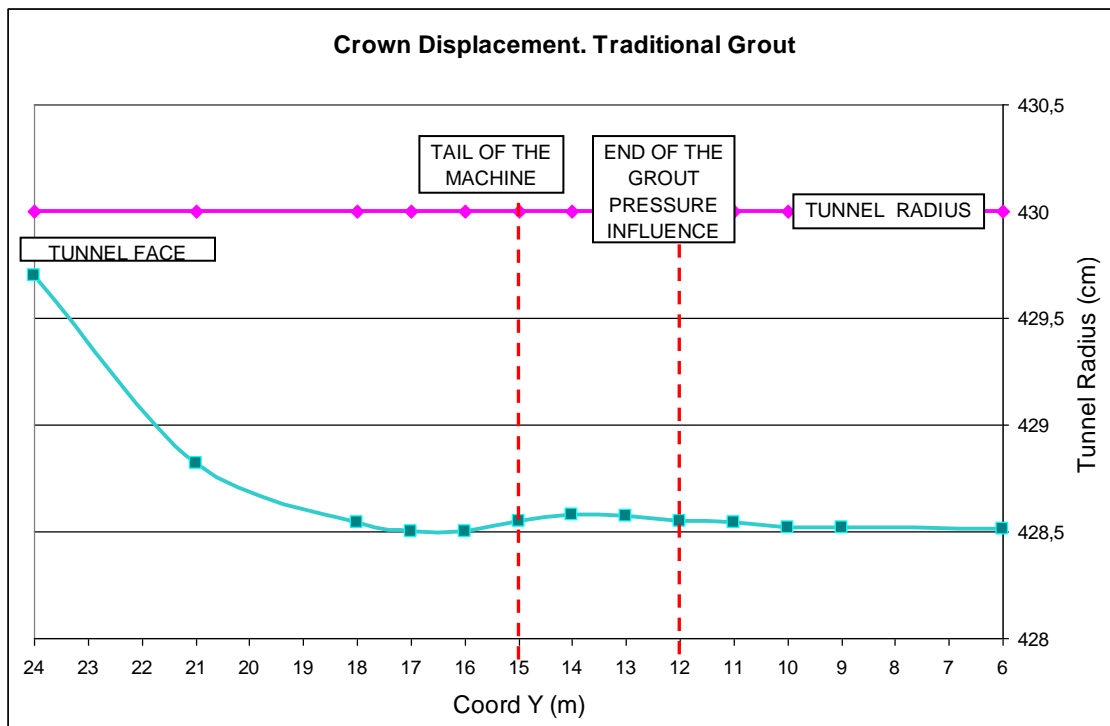

Figure 86 Crown Displacements for traditional grout

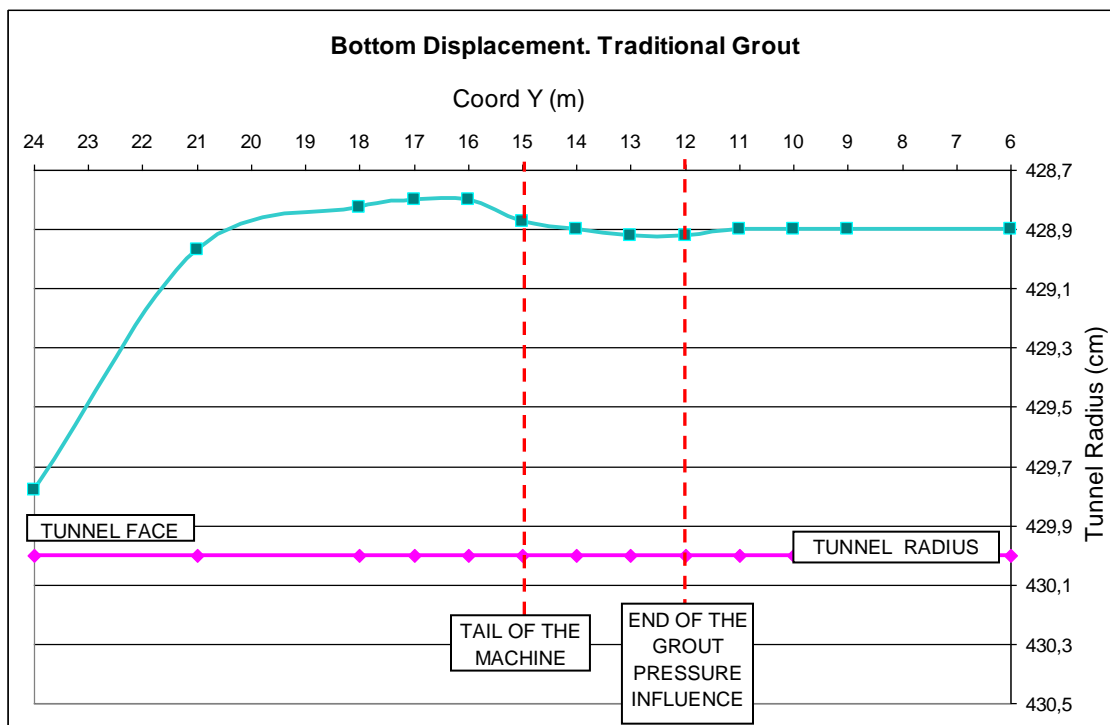

Figure 87 Bottom displacements for traditional grout

3.5.2 Two Component Grout

3.5.2.1 Transversal Subsidence:

Respect to the two component grout case, the maximum subsidence is 6,6mm. The distribution of the settlements related to the distance from the tunnel axis is exposed in *Table 33* and *Figure 88*. The calculated volume loss inside the tunnel is 0,49% and the V_s is 0,64 V_{loss} like the traditional grout case. Consequently the ground loss ratio (GLR) is 0,31%.

PLANE Y=0		PLANE Y=12		PLANE Y=24		PLANE Y=60	
X-coord (m)	Zdis (mm)	X-coord (m)	Zdis (mm)	X-coord (m)	Zdis (mm)	X-coord (m)	Zdis (mm)
0	6,61	0	5,85	0	3,95	0	0,48
6	6,2	6	5,49	6	3,68	6	0,43
12	5,12	12	4,51	12	3,15	12	0,38
18	3,8	18	3,39	18	2,25	18	0,32
24	2,65	24	2,35	24	1,65	24	0,26
30	1,84	30	1,64	30	1,16	30	0,2
36	1,18	36	1,035	36	0,768	36	0,16
42	0,795	42	0,705	42	0,505	42	0,11
48	0,527	48	0,472	48	0,39	48	0,097
54	0,42	54	0,371	54	0,2655	54	0,06
60	0,353	60	0,338	60	0,235	60	0,03

Table 33 Transversal Subsidence for Two components grout case

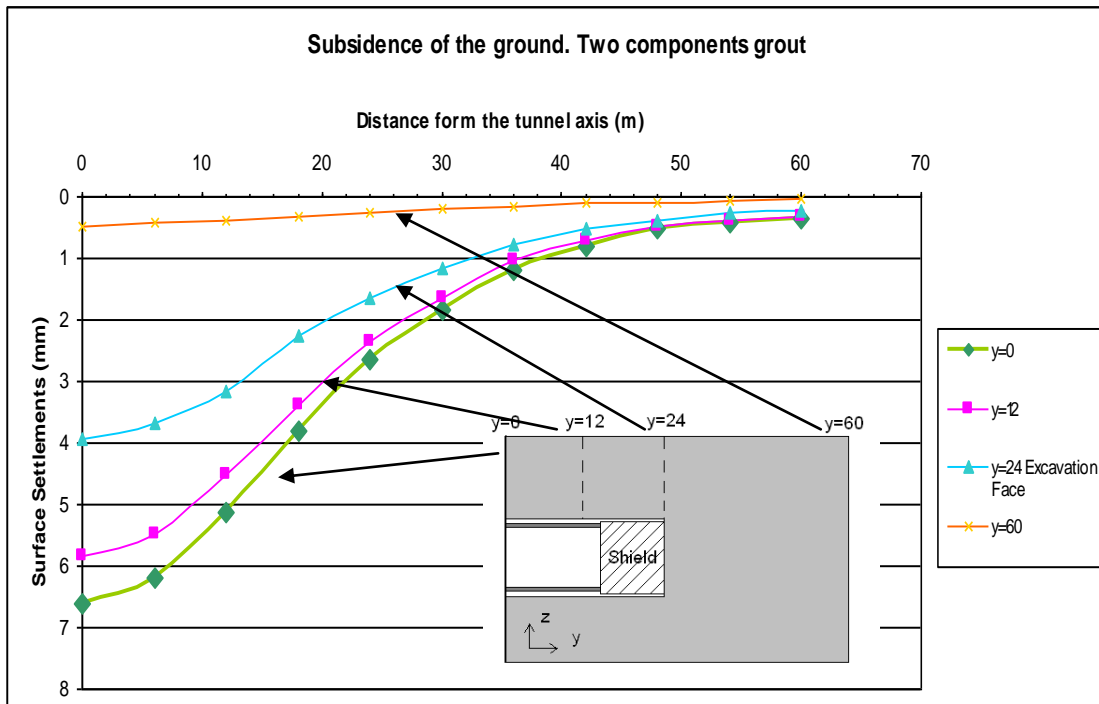

Figure 88 Subsidence diagram for two components grout case

3.5.2.2 Longitudinal subsidence:

The displacements in this direction for the two component grout is very similar to the traditional case (Figure 89). The settlement above the face of the tunnel was 3,95mm and at the last part of the machine was 5,46mm (60% and 83% of the total subsidence respectively).

3.5.2.3 Longitudinal Deformations inside the tunnel

The displacements inside the tunnel for the two component grout are showed in Figure 90 and Figure 91. These are governed by the relaxation of the soil into the steering gap during the passage of the machine, where is reached the total deformation amount. The grout injection leads to the absolute control of the successive deformations and consequently the restraining of the subsidence.

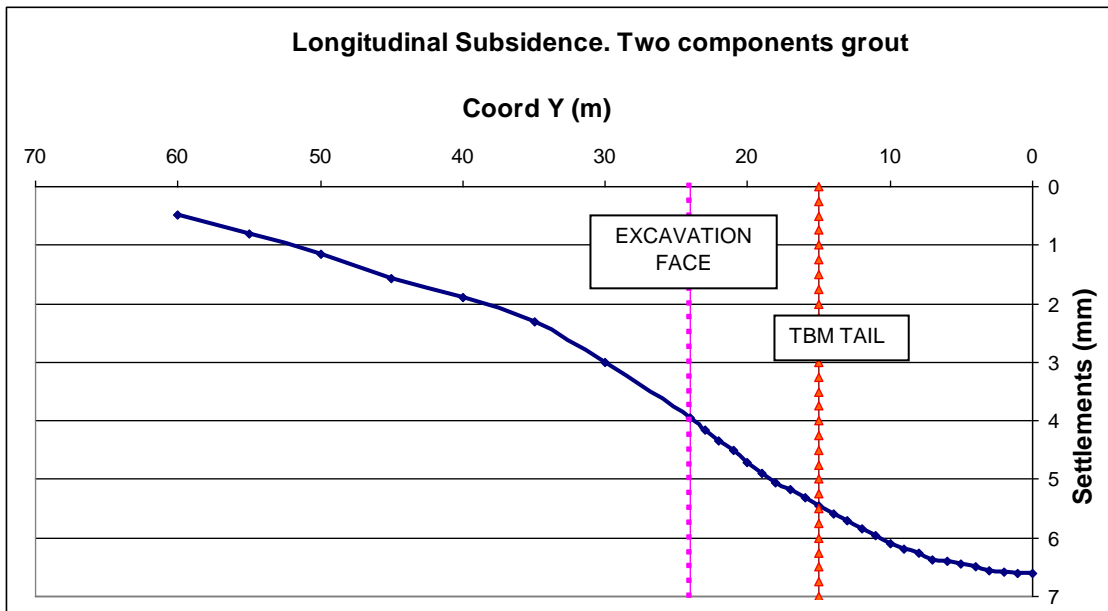

Figure 89 Longitudinal Subsidence. Two components grout

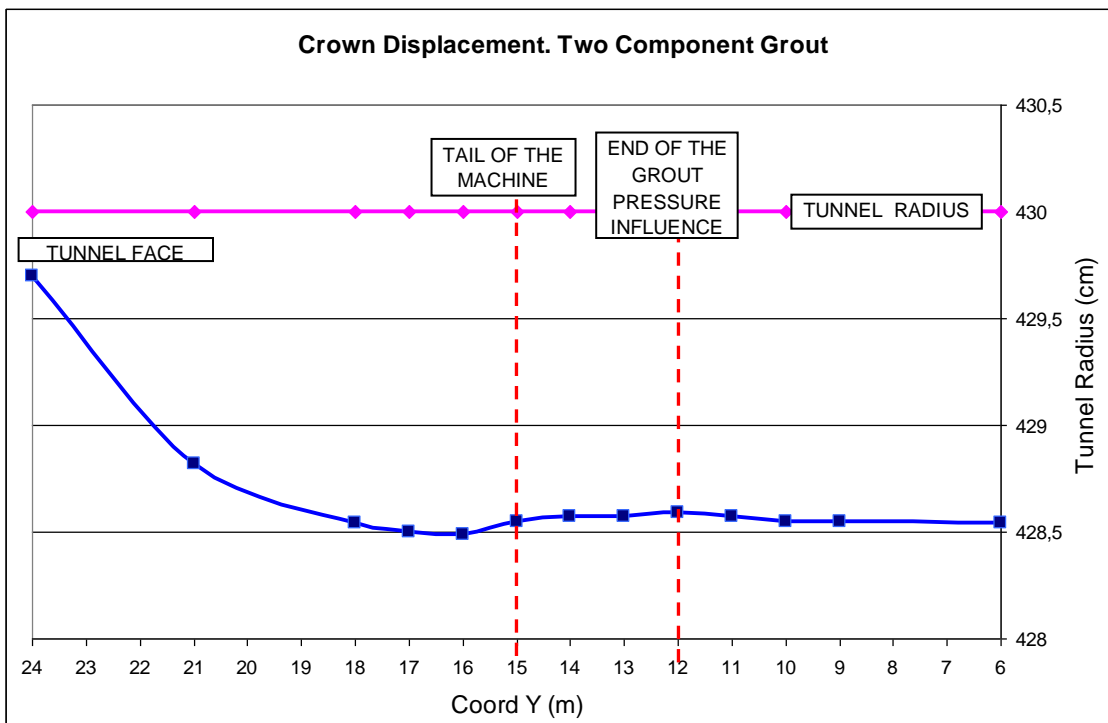

Figure 90 Crown Displacements for two component grout

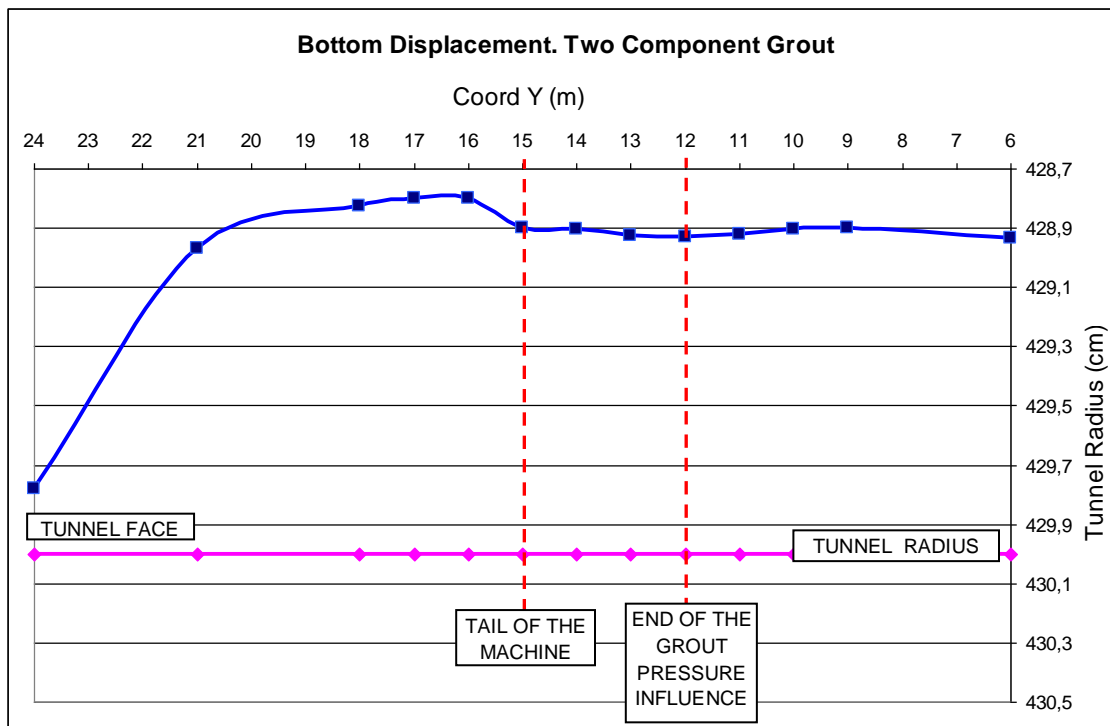

Figure 91 Bottom displacements for two component grout

3.5.2.4 No backfill grouting.

3.5.2.5 Transversal Subsidence:

The maximum surface settlement when the tail void injections are not considered is 11,4mm. The distribution of the displacements is reported in *Table 34* and *Figure 92*. The volume loss into the tunnel was calculated in 0,78%, and the yield surface volume (V_s) was 0,75 V_{loss} . As a result, the ground loss ratio (GLR) was estimated in 0,59%.

3.5.2.6 Longitudinal subsidence:

The longitudinal settlements follow the normal distribution (*Figure 93*). Above the excavation face, the subsidence is 6,75mm, the 60% of the total subsidence. The surface settlements increase until 9,2mm, related with the tail of the machine (80% of the total displacement).

TUNNELLING WITH FULL FACE SHIELD MACHINES: Study of the backfill of the tail void

PLANE Y=0		PLANE Y=12		PLANE Y=24		PLANE Y=60	
X-coord (m)	Zdis (mm)	X-coord (m)	Zdis (mm)	X-coord (m)	Zdis (mm)	X-coord (m)	Zdis (mm)
0	11,4	0	9,08	0	6,18	0	0,635
6	10,78	6	9,04	6	6	6	0,615
12	8,9	12	7,68	12	4,75	12	0,56
18	6,35	18	5,43	18	3,25	18	0,46
24	3,97	24	3,42	24	2,27	24	0,32
30	2,43	30	2,165	30	1,35	30	0,247
36	1,58	36	1,405	36	1,055	36	0,19
42	1,04	42	0,94	42	0,705	42	0,16
48	0,705	48	0,64	48	0,49	48	0,135
54	0,55	54	0,505	54	0,39	54	0,125
60	0,49	60	0,45	60	0,34	60	0,1

Table 34 Transversal Subsidence for no backfill grouting case

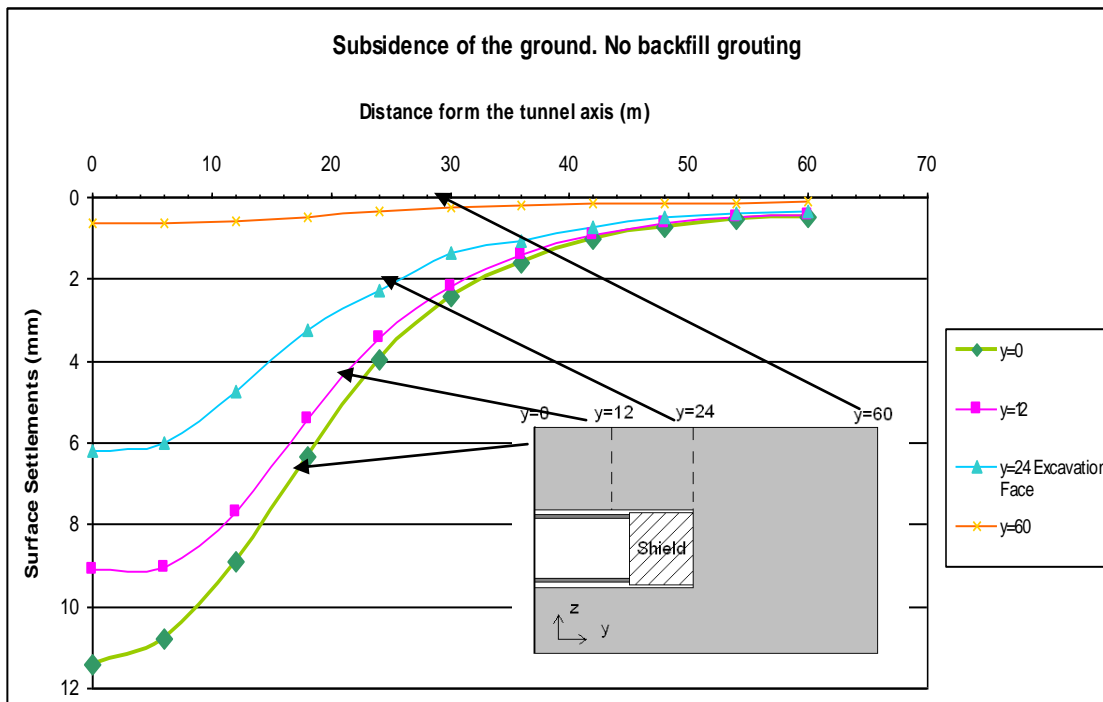

Figure 92 Subsidence diagram for no backfill grouting case

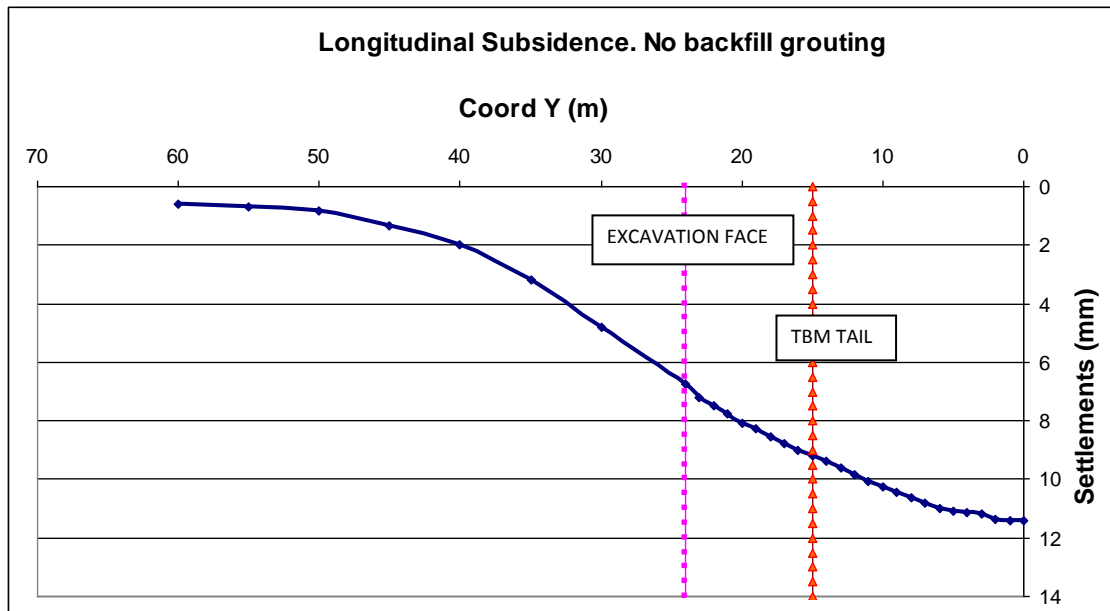

Figure 93 Longitudinal Subsidence. No backfill grout

3.5.2.7 Longitudinal Deformations inside the tunnel

When the tail void grouting is not taken into account, the soil can deform into the annular gap. The crown and bottom displacements are exposed in *Figure 94*, *Figure 95* and *Figure 96*. In this case, the soil is able to relax, not only into the overcutting zone, but also above the lining. When the excavation face arrives, the crown displacement is 3,6mm. After that, the ground gets into the steering gap, until a deformation of 2cm. Since not grout is being applied, the soil continues to move, and the deformation after 4 rings is 2,88cm. After 10 rings, the ground has deformed 3,4cm, and because of the modelled situation regard loose soil, is likely that the complete annular cavity ends filled (7cm). The fact that no steady value is found, as for example in the traditional and two component cases, corroborates it. This final deformation is not reflected in this simulation because was limited to 10 rings, due to the time factor, and also, because the grout and overcutting zones, even if they have low resistance, they still have some, and the deformation occurs gradually, needing several steps to be concluded.

If it is assumed that the 7cm displacement is reached, the volume loss into the tunnel would be 2%. Using the relation between V_s and V_{loss} , reported in the transversal subsidence section ($V_s=0,75V_{loss}$), the V_s can be estimated. With the theory equation that correlates the maximum surface settlement and the V_s , the maximum subsidence would be 3cm, with a ground loss ratio (GLR) of 1,5%.

TUNNELLING WITH FULL FACE SHIELD MACHINES: Study of the backfill of the tail void

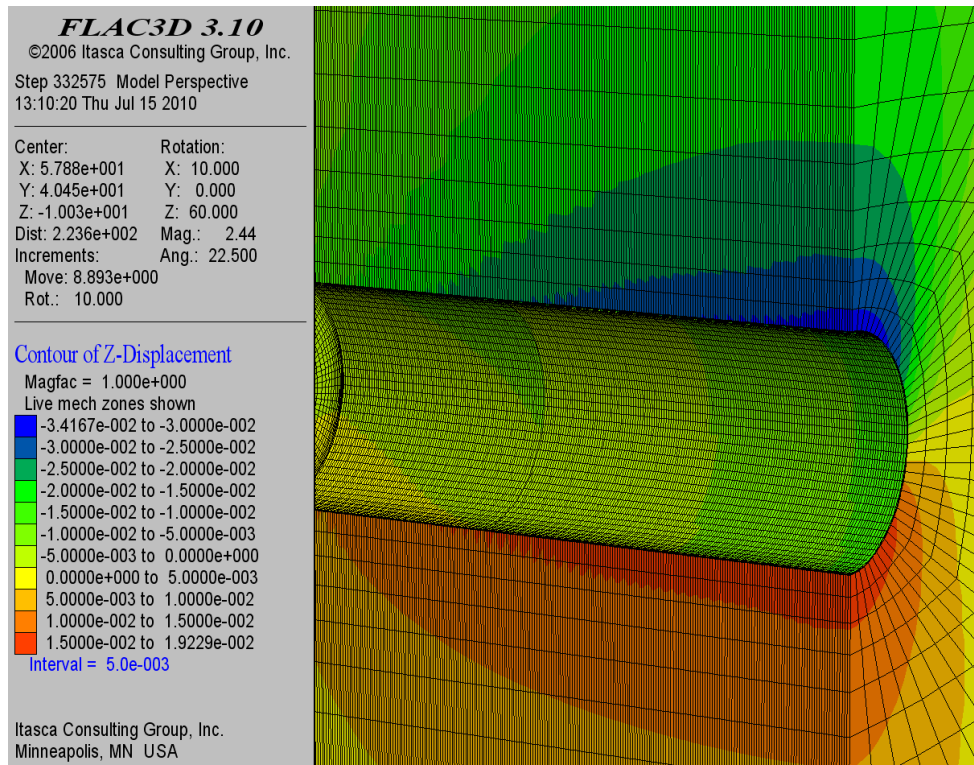

Figure 94 Z-displacements for no backfill case

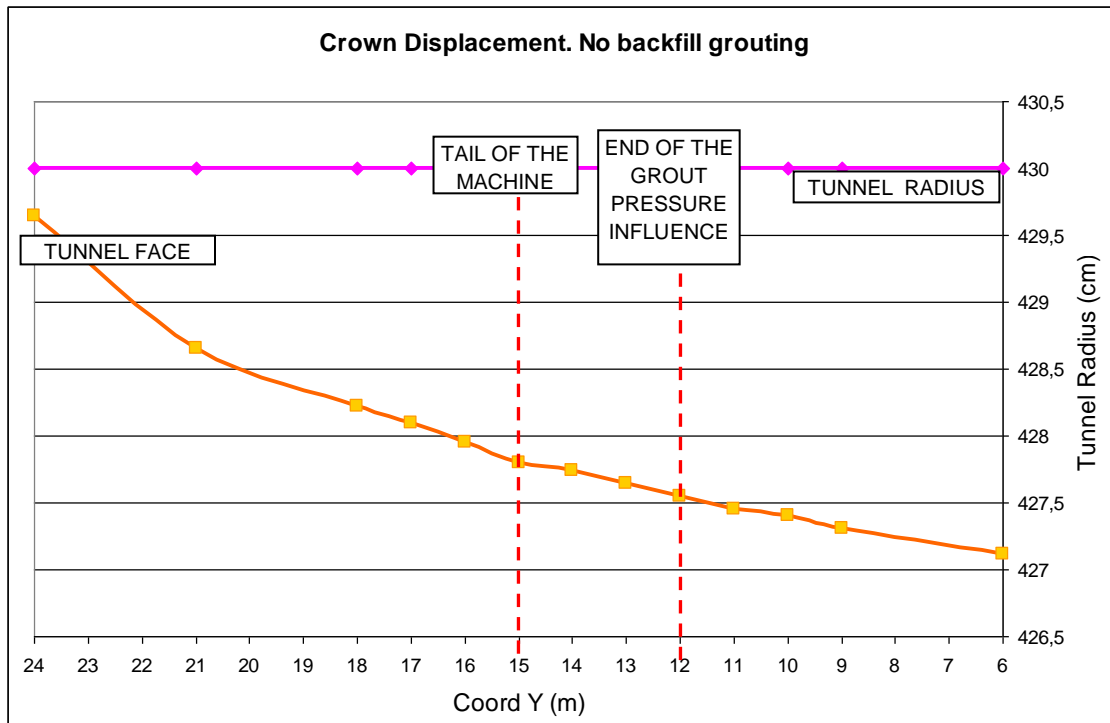

Figure 95 Crown displacement for no backfill grouting

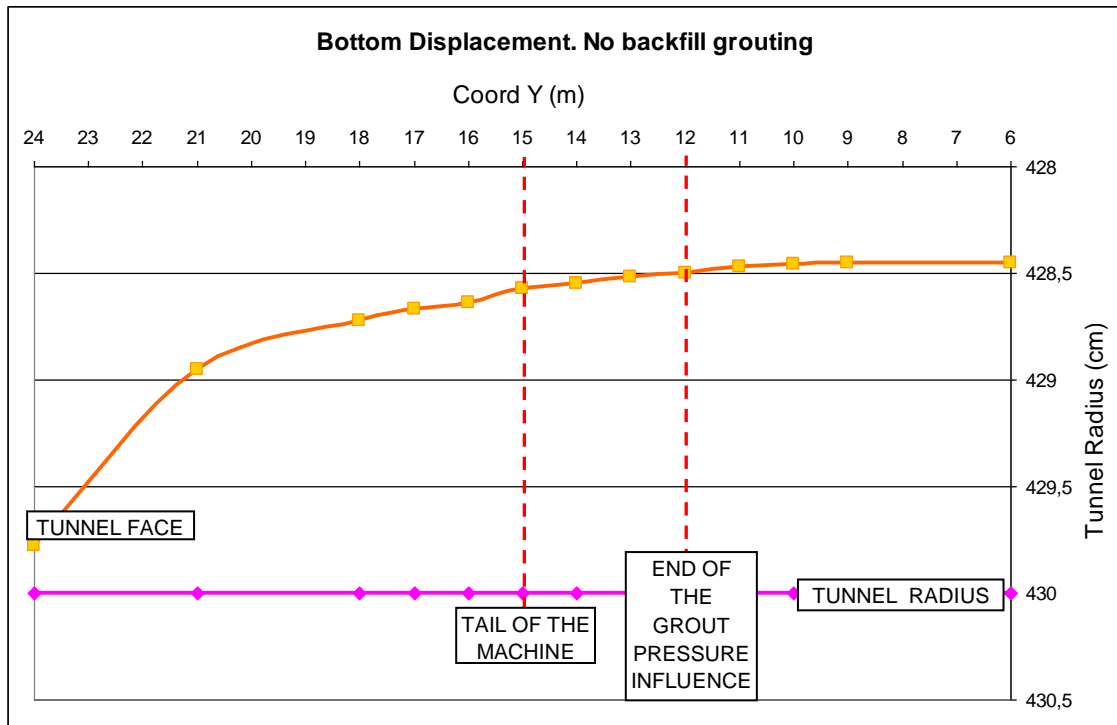

Figure 96 Bottom displacements for no backfill grouting case

Discussion:

The 3D simulation of the tunnel construction was made with the aim of study the influence of the grout material in the performance of the excavation, its influence on the subsidence and in the volume loss control.

In addition, the numerical model is a way to understand the theoretical behaviour of the surrounding soil as reaction of the injection pressures and its variation.

The researches that regard the stages from the assembling of the lining to the hardening of the grout are limited, and no difference has been made between the grouting materials. This model was designed to show the influence of the hardening time, of the rigidity of the mix and of the injection pressure.

The developed model did not show a relevant difference between the normal mortar and the two components mix. This can be induced by the fact that it was followed a theoretical approach, in which some significant factors were underestimated or idealized, for instance: the time in which the annular gap is filled, the shrinkage of the mortar by the consolidation or hardening, the inefficient filling of the grout, etc.

Besides, the simulation probably overestimate the effect of the injection pressure, since this pressure control and prevents the deformation of the ground particularly in the most critical phase, that is behind the tail. This pressure reduction is difficult to be evaluated because there is not available data and it is very much influenced by the shape of the tail void (over excavation, soil detachment, etc.), the relation between the soil and grout rigidities, the initial injection pressure, etc.

The research shows that a better evolution of this parameter has to be carried out and can be a future development of research.

The computed longitudinal settlements obtained for the three studied cases (no grout, traditional mortar and two component grout) are in good agreement with the theoretical approach (Craig et al, 1978) (Möller, 2006). The obtained surface settlements are linked with the position of the TBM face: the 60% develops ahead of the face; the 20% along the shield and the remaining 20% after the tail.

When the tail void grouting is not practiced the crown displacements can arrive to the total annular gap dimension. In that case, the distribution of the crown movements is 5% ahead the face, 23% due to the overcutting, and the relief along the shield, and 72% as consequence of the void deformation. Instead, applying the backfill grouting, the crown displacements at the tail are totally controlled, with almost null deformations, being 5% at the excavation face and 95% caused by the overcutting and tapering of the shield.

TUNNELLING WITH FULL FACE SHIELD MACHINES: Study of the backfill of the tail void

This diagrams (Figure 97, Figure 98 and Figure 99) shows clearly that the backfilling is important, since if the void is not correctly filled the induced displacement can be about some centimetres. The subsidence for the grouted cases is calculated in 6,61mm; instead for the no grouted case after 10 rings, when the convergence was not still reached it was obtained 11,4mm. If it is considered the complete release of the soil into the tail void, the subsidence arrives to 3cm, more than 4 times higher than the maximum computed displacement (300%-400% bigger than when the backfill is appropriately done).

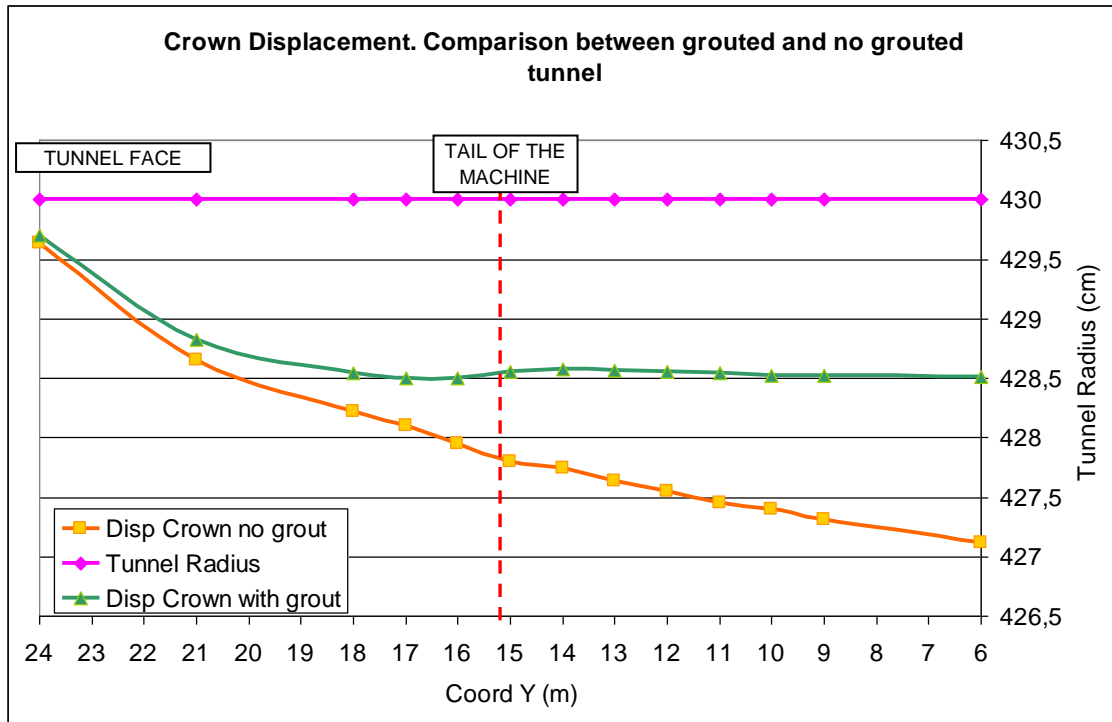

Figure 97 Crown displacement. Comparison between grouted and no grouted tunnel

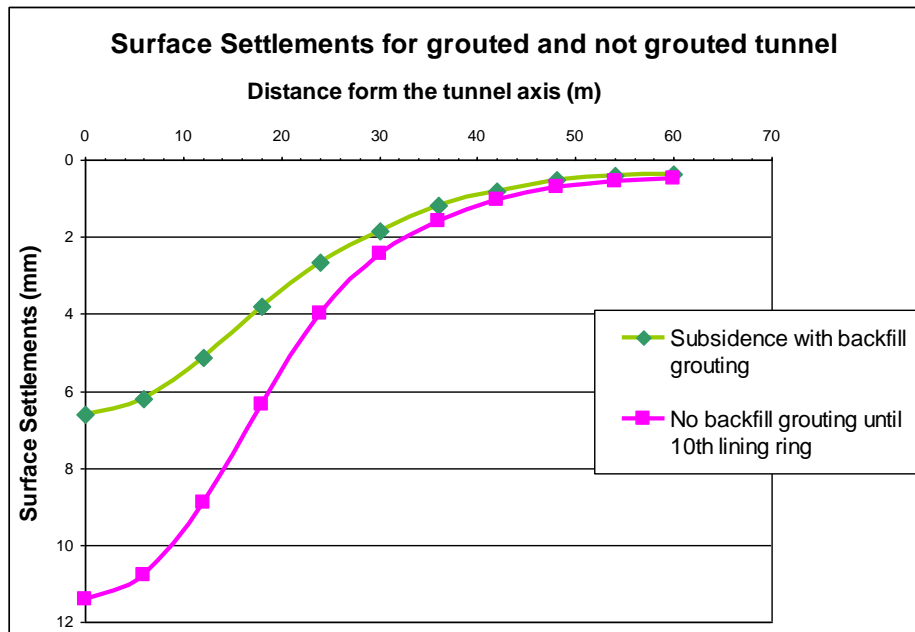

Figure 98. Transversal Surface Settlement. Comparison between grouted and no grouted tunnel until 10th ring

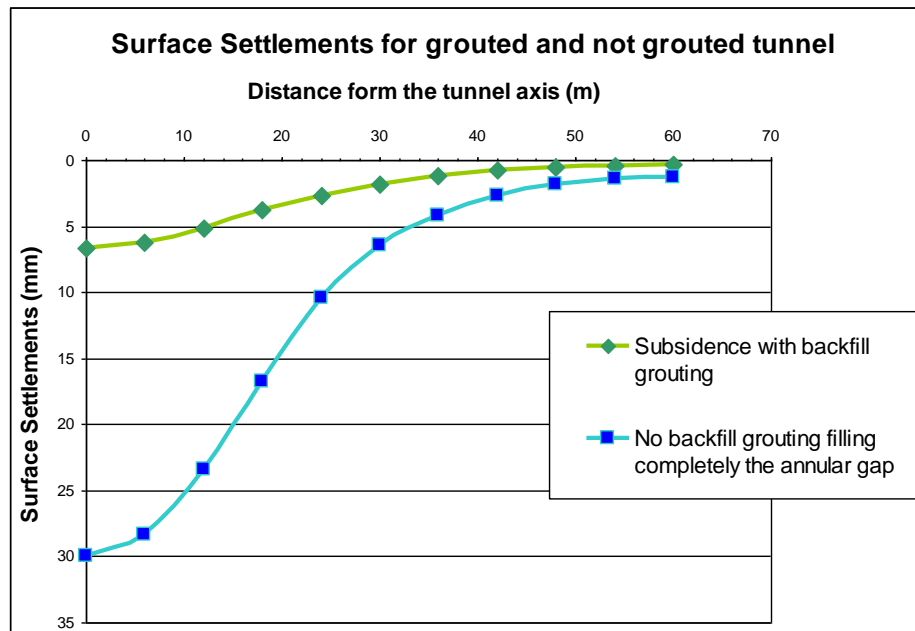

Figure 99 Transversal Surface Settlement. Comparison between grouted and no grouted tunnel.

CONCLUSIONS

The practice of the backfill grouting at the tail of shield machines is of great importance, since it prevent the detachment of the soil into the annular gap and counteract the relaxation of the ground. Through this practice is possible to reduce the volume loss inside the tunnel and consequently the yield volume at the surface, decreasing the subsidence. For instance in the present study it is found that the settlements can arrive to values 300% higher if the tail void is not filled.

Since the subsidence is significantly reduced with the use of the simultaneous backfill grouting at pressurized face machines, the underground construction field have extended considerably, permitting the tunnel excavation in urban areas. It is, beyond the technical advance, a contribution to the social, cultural and economical development of the cities.

In this context it is essential to find the ways to optimize the application of the mortar, because the efficiency of the backfill procedure is largely linked with the operational factors. For the appropriate performance of the tail injections it is necessary to fill completely and uniformly the void, bedding immediately the lining rings, therefore it is essential the fluidity and workability of the material. Moreover, it

is indispensable the injection pressures control, to avoid the inclusion of material into the tunnel, but also the uplift of the ground, and the crumble of the walls.

Respect to the traditional mortar, the injection pressure selection must take into account the penetration of the grout into the steering gap. The analysis done in this study permits to estimate the grout behaviour around the shield, calculating the relation between the overcutting, the grout pressure and the scope of the grout material. It was highlighted that the steering gap size is the most restrictive factor, since the smaller it is, the smaller the grout penetration, as consequence of the high shear forces that act against the grout material. However, sometimes it is necessary a large overcutting, in order to improve the maneuverability, and the grout introduction between ground and shield is inevitable. To this matter, it can be considered the injection of some lubricating compounds through the shield of the machine, obtaining:

- the control of the volume loss caused by the overcutting;
- the restriction of the penetration of the grout into the previously mentioned cavity.

The calculation method developed can be the first step for more deep studies, which would take consideration more complex hypothesis, constitutive models, etc.

In addition, the verification of the TBM brushes, and the grease seals regarding the injection pressures might also be included in future studies of the backfill grouting. Although it is not recognize as a representative limiting factor, the leakage of liquid into the machine must be examined.

The investigation carried out in technical literature showed that the early stages properties are more important than the long term ones, since:

- it is necessary to avoid the bleeding of the mortar, without and under pressure, since the reduction of the grout volume give some extra space to the soil to deform, and this can influence the subsidence;
- the grout must have large yield stress, to counteract the buoyancy effects, but at the same time good workability for the appropriate application;
- the quick development of resistance is a desirable feature to minimize the settlements;

However, the long term resistance is relevant to inhibit long term settlements, but the grout just have to resist the ground and water load without fissuring, given that the real structural function is carried by the lining. The most important long term property for the grout materials is the durability. The chemical stability of the grout is absolutely necessary.

Regarding the different options of grouting materials and methods, it is advice to analyze carefully the different types of mortars accordingly the project characteristics, with the aim of finding the most convenient material for that particular situation.

When the material is selected, it is important to establish the optimal features required and the most favorable dosage. Beyond the type of mortar, the mix design can guarantee the success or the failure of the work. Additionally to the adequate mix dosage, the laboratory tests are of vital importance. This is the only way to be sure that the planned performance will be reach, and that all the preparation steps are been done correctly.

With reference of the numerical modelling of the grouting materials it is necessary to consider the remarkable complexity of this task. In the present research they were modelled two different procedures and materials, trying to focus the quality of the obtained results.

The models have highlighted the great importance of the backfilling, showing that the excavation with backfill grouting produced 6,6mm of surface settlements, instead without grout is reached 11,4mm for the 10th ring, until 3cmm, if the soil collapses into the annular gap.

Additionally, the study has showed the operative difficulty to model the injections and the two component grout behaviour, since the results are highly dependent of the chosen the injection pressures trend. This hypothesis is not based in real data, because its measurement is very complex.

Nevertheless, it is remarkable the importance of the immediate gel formation and the quick harden time of the two component grout in the surface settlement control.

The research has also allowed considering some significant aspects for the better understanding of the backfill grouting phenomenon, its optimisation and necessities to future studies:

- the better knowledge of the rheological properties of the grout and the normalisation of the laboratory tests;
- the characterisation of the two components backfill grout during curing and after it hardens. The elastic properties of the material at short and long term are necessities for the numerical simulation of its performance;
- the knowing of the pressure distribution around the lining, its variation as a function of time and distance to the TBM, until the long term;
- the pressure upon the lining in terms of the injection strategy and type of soil;

- the buoyancy effect on the longitudinal direction of the tunnel.

REFERENCES

Barla, G; Barla, M; Bonini, M.; Gamba, F. 2005. 11th International Conference of IACMAG Torino, June 19-24, 2005, 2005, Vol. 2.

Bezuijen, A; Talmon, A.M; 2003. Grout the foundation of a bored tunnel. Proc. ICOF. Dundee

Bezuijen, A; Talmon, A.M; 2004. Grout pressures around a tunnel lining, influence of grout consolidation and loading on lining. Proc. ITA, Singapore.

Bezuijen, A; Talmon, A.M; Kaalberg F.J. and Plugge, R; 2004. Field measurements of grout pressures during tunneling of the Sophia Rail tunnel. Soils and Foundations. Vol 44. No 1, 39-48

Bezuijen, A; Talmon, A.M; 2006. Grout Properties and their influence on back fill grouting. Geotechnical Aspects of Underground Construction in Soft Ground. pp 187-193.

Bezuijen, A. 2007. Bentonite and grout flow around a TBM. Underground Space- the 4th Dimension of Metropolises. pp 383-388

Bezuijen, A; W.H van der Zon. Volume changes in grout used to fill up the tail void. Underground Space- the 4th Dimension of Metropolises.

Bezuijen, A.; Bakker, K.J. 2009. The influence of flow around a TBM machine. Geotechnical Aspects of Underground Construction in Soft Ground. pp 255-259.

Billing, B; Ebsen, B; Gipperich, C; Schaab, A; Wulff, M.2007. DeCo grout. Innovative grout to cope with rock deformation in TBM tunnelling. Underground Space- the 4th Dimension of Metropolises.

Biosca, F.; Bono, R. 2008. Construcción de la línea 9 del metro de Barcelona. Obras Urbanas magazine.

Boumiz, A; Vernet, C; Cohen Tenoudjit, F. 1996. Mechanical Properties of Cement Pastes and Mortars at Early Ages. Elsevier Science Inc.

Castellanza, R; Betti, David; Lambrugh, Angelo. 2005. Three-dimensional numerical method for mechanized excavations in urban areas.

Drury Greenwood, J. Master Engineering Thesis: Three-dimensional analysis of surface settlement in soft ground tunnelling. Massachusetts Institute of Technology. 2003.

FLAC3D Tutorial. Itasca, Inc. 2006

Feddema, A; Möller, M; van der Zon, W.H.; Hashimoto, T. 2001. Tunnelling: A decade of progress. GeoDelft 1995-2005. Pp 19-24

Fengshou Zhang; Xiongyao Xie; Hongwei Huang. 2010. Application of ground penetrating radar in grouting evaluation for shield tunnel construction. Tunnelling and Underground Space Technology. Pp 99-107

Guglielmetti, V; Grasso, P; Mahtab, A; Shulin Xu. Mechanized Tunnelling in Urban Areas. Taylor & Francis. 2007.

Guidelines for the Design of Shield Tunnel Lining
Working Group No 2, International Tunnelling Association. 2000

Hashimoto, T; Brinkman, J. 2004. Simultaneous backfill grouting, pressure development in construction phase and in long term. Proc. ITA, Singapore.

Hashimoto, T; Ye, G.L.; Nagaya, J.; Konda, T. 2009. Study on earth pressure acting upon shield tunnel lining in clayey and sandy grounds based on field monitoring. Geotechnical Aspects of Underground Construction in Soft Ground. pp 307-312

Herrenknecht, M; Böppler, K. 2003. Segmental concrete lining design and installation. Soft Ground and Hard Rock Mechanical Tunneling Technology Seminar.

Hoefsloot F.J.M.; Verweij A. 2005. 4D Grouting pressure model PLAXIS. Geotechnical Aspects of Underground Construction in Soft Ground, pp. 529–534.

Maidl, B; Herrenknecht, M; Anheuser, L. Mechanised Shield Tunnelling. 1995

Linger, L; Cayrol, M; Boutillon, L. 2008. TBM's backfill mortars- Overview- Introduction to rheological index. Tailor made concrete structures.

Peck, R.B. 1969. Deep excavations and tunnelling un soft ground. Proc., 7th Int. Conf. Soil Mech. Found. Engrg., 225-281

Peila, D. 2009. Appunti di Costruzione di Gallerie. Politecnico di Torino

Pelizza, Sebastiano. 2009. Nota Tecnica in merito alla Retroiniezione Longitudinale istantanea attive a due componenti utilizzata in unione allo scavo delle gallerie con TBM-EPB.

Pelizza, S; Peila, D; Oreste, P; Oggeri. 2009. Appunti di Gallerie. Politecnico di Torino.

Pellegrini, L; Perruzza, P. 2009. Sao Paulo Metro project-Control of settlements in variable soil conditions through EPB Pressure and bicomponent backfill grouting.

Schmidt, B. 1969. Settlements and ground movements associated with tunnelling in soil. PhD thesis, University of Illinois.

Shirlaw J.N.; Richards D.P.; Ramon, P.; Longchamp, P. 2004. Recent experience in automatic tail void grouting with soft ground tunnel boring machines. Proc. ITA, Singapore.

Talmon, A.M.; Aanen, L.; Bezuijen, A.; W.H van der Zon. 2001. Grout Pressures around a tunnel lining. Proc. IS-Kyoto conference on Modern tunneling Science and Technology, pp. 817-822

Talmon, A.M; Bezuijen, A. 2006. Grouting the tail void of bored tunnels. The role of hardening and consolidation of grouts. Geotechnical Aspects of Underground Construction in Soft Ground. pp 319-325.

Talmon, A.M; Bezuijen, A. 2009. Simulating the consolidation of TBM grout at Noordplaspolder. Tunnelling and Underground Space Technology. pp.493-499

Talmon, A.M; Bezuijen, A. 2009. Processes around a TBM. Geotechnical Aspects of Underground Construction in Soft Ground. pp 3-13.

Telford, T. Closed-face tunneling machines and ground stability. London, 2005

Thewes, M; Budach, C. Grouting of the annular gap in shield tunneling- An important factor for minimization of settlements and production performance.

Verrijujt, A. 1993. Soil Dynamics, Delft University of Technology.

Wittke, Walter. Stability Analysis and Design for Mechanized Tunnelling. WBI-PRINT6. 2007

Yue-wang Han; Wei Zhu; Xiao-chun Zhong; Rui Ja. 2007. Experimental investigation on backfill grouting deformation characteristics of shield tunnel in sand. Underground Space- the 4th Dimension of Metropolises. pp 303-306

http://www.rheologyschool.com/vane_shear_test.html last revision 20th June 2010